

GSM Based Generator Monitoring System for Steel Melting Shop (SMS)

S. Boopathi¹, M. Jagadeeshraja², L. Manivannan³ and M. Dhanasu⁴

¹Department of Electrical and electronics engineering, Knowledge Institute of Technology, Salem, India

²Assistant Professor, Knowledge Institute of Technology, Salem, India

³Assistant Professor, Knowledge Institute of Technology, Salem, India

⁴Assistant General Manager (CEM), Steel Authority of India, Salem, India

Abstract

Steel making processes are highly energy intensive and comprised of many complex unit operations. Iron ore and coal need preprocessing before feeding into a reactor, and molten metal from different reactors needs to be carefully drawn into a solid metal and then rolled into sheets. Each of these operations has a stake in the quality of steel produced, and needs constant monitoring and need continuous power supply for fabrication. If a power failure occurs the production will be stopped, time delay increases for finishing fabrication. In some cases we can loss consumer due to unsatisfactory. My Project focuses the detection of power failure and takes reflex action to solve the problem with help of modem communication using GSM. The power failure will be intimated to the Microcontroller it drive the GSM modem to send a text message to the concern person mobile number which was already programmed in Microcontroller and also monitoring the parameter are temperature, oil level, fuel level and when they exceed predefined limits an automatically intimated to authorized person and also This system can be designed to send SMS alerts whenever the Circuit Breaker (Relay) trips and simulation result done by using LabVIEW software.

Keywords: Microcontroller, GSM, Sensors, LabVIEW.

1. Introduction

The use of Generators has become a very common in almost using every infrastructure companies, Industries, hospitals, Townships etc. as the application of generators has become common the problems occurred in using them have also become very common such as low fuel, High temperature and these problems can be solved by continuous monitoring of generator, a system which can remotely monitoring generator and provide you all the information through mobile.



Figure 1. GSM based Power Failure Indicator

The GSM a monitor the power generator placed at the remote areas and increases its efficiency by monitoring the various parameters of generator, Reporting critical Problems minimizes downtime and maximizes availability by sending if any failure in generator through messages instantly to diagnosis and emergency service dispatch if

required and the GSM is used in standby, prime and rental power applications. This system provides ideal solution to the problems caused in situations when a wired connection between a remote appliance/device and the control unit might not be feasible. The project is aimed to analyzing and testing the use of mobile phones to remotely monitor an appliance control system through GSM based wireless communication. The Microcontroller would then control a device based on the information given to it.

2. Literature Survey

Amit sachen et al have discussed the user can send commands in the form of SMS messages to read the remote electrical parameters. This system also can automatically send the real time electrical parameters periodically (based on time settings) in the form of SMS. This system can be designed to send SMS alerts whenever the Circuit Breaker trips or whenever the Voltage or Current exceeds the predefined limits. This project makes use of an onboard computer which is commonly termed as microcontroller [1].

Mallikarjun et al proposed this system is a specially designed computer system that is completely encapsulated by the device it controls. The embedded system has specific requirements and performs pre-defined tasks. The diesel generator is used when electricity is not readily available, or when power failures occur due to natural disasters such as typhoons or floods, or during other unexpected crises. Generally, the diesel generator operates in analog. The analog type controller cannot be processed precisely due to the distortions and noises coming from the data. In order to increase data accuracy, the controller needs to be digitalized [2]

Vimalraj et al have described a distribution transformers have a long service life if they are operated under good and rated conditions. However, their life is significantly reduced if they are overloaded, resulting in unexpected failures and loss of supply to a large number of customers thus effecting system reliability. This system provides flexible control of load parameters accurately and also provides effective means for rectification of faults if any abnormality occurs in power lines using SMS through GSM network [3].

Andriy Palamar et al proposed the system the Cellular phone containing SIM (Subscriber's Identifying Module) card has a specific number through which communication takes place. The mode of communication is wireless and mechanism works on the GSM (Global System for Mobile communication) technology. Here, the communication is made bi- directional where the user transmits and also receives instructions to and from the system in the form of SMS [4].

Kwang Seon Ahn et al have discussed the Using remote management; you can check operating hours, oil pressure, battery status, coolant temperatures, generated power output, fuel level, GPS position and more. A notification also could be generated whenever a critical level has been reached, such as when a generator has been running more than expected, or when the running hours exceed the service interval [5].

Henrik Arleving proposed system by using a cloud-based remote management solution with a communication gateway can help reduce costs, avoid fuel theft and improve power generator control. It can be difficult to focus on the right actions, simply because there isn't enough information on fuel levels, oil pressure or battery status for each generator. With a cloud-based remote management solution, we can have immediate access to generator parameters via a regular web browser being able to analyse each generator remotely enables you to better understand their health and more efficiently schedule field service visits and Fuel theft can be a significant problem[6].

Chetan Patil et al have discussed the design of BTS safety and fault management system the measures are taken to rectify these problems. The method makes use of GSM modem which gives the instant message about the each activity happening in the site. The temperature sensors will sense the temperature of the room and if it rises above the

threshold value the GSM module will send the message to the master mobile which is already set in the system [7].

Y Jaganmohan Reddy et al is discussed the model of combination of Photo Voltaic (PV) cell System, Wind turbine system, Fuel cell (FC), and Battery systems for power generation, and to improve power quality they proposing Motor-Generator model instead of using static converters, and an energy management and control unit using Programmable Logic Controller (PLC). This system facilitates improvement in power quality, which ensures continuous and reliable supply to loads. The power transformer is regarded as the heart of any electrical transmission and distribution system. At the output of the generator, they are used for stepping up voltage for transmission [8].

A.P.Agalgaonkar et al have discussed the measurement and control of temperature, humidity and the other parameters at different places. The Data Acquisition is defined as the process of taking a real-world signal as input, such as a voltage or current any electrical input, into the computer, for processing, analysis, storage or other data manipulation or conditioning[9].

3. Block Diagram

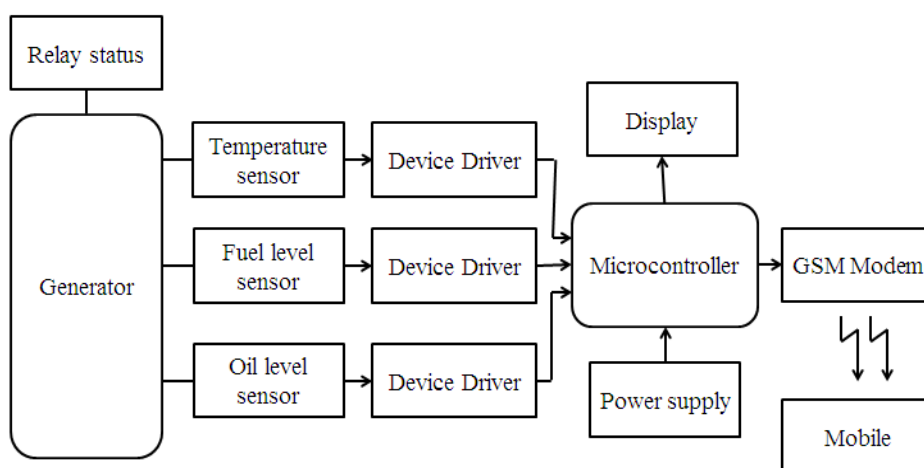

Figure 2. Block Diagram of Proposed System

4. Description of Proposed Method

The Real-time point-to-point data reporting architecture is useful for remote surveillance and control, if communication network can be convenient to access. In the new age of technology, mobile phone redefines communication. The worldwide trend for wireless communication has elevated into wide band data instead of voice only. Sending written text messages is very popular among mobile phone users. We have used the embedded based control the generator plant from a remote area. Remotely the user can establish effective monitor and control via the mobile phone set by sending commands in the form of SMS. This system provides ideal solution to the problems caused in situations when a wired connection between a remote appliance/device and the control unit might not be feasible.

The generator monitoring system is useful because of the following reasons;

- It gives awareness of the power stability and the behavior of power supply thus one can be able to deal with the problem of constant power outage by looking for Alternative means of power supply

- It records the time of the duration and in the process letting someone know in advance the effect of the damage caused by the power outage
- If one is far-away from the microcontroller based monitoring unit, with the facilities of reporting the failures to a central control via GSM module, one can be able to respond to the situation as soon as possible.

4.1 Microcontroller:

89c52: The AT89C52 is a low-power, high-performance CMOS 8-bit microcontroller with 8K bytes of in-system programmable Flash memory. The device is manufactured using Atmel's high-density non-volatile memory technology and is compatible with the industry standard 80C51 instruction set and pin out. The on-chip Flash allows the program memory to be reprogrammed in-system or by a conventional non-volatile memory programmer. By combining a versatile 8-bit CPU with in system programmable Flash on a monolithic chip, the Atmel AT89C52 is a powerful microcontroller, which provides a highly flexible and cost-effective solution to many, embedded control applications. The AT89C52 provides the following standard features: 8K bytes of Flash, 256 bytes of RAM, 32 I/O lines, Watchdog timer, two data pointers, three 16-bit timer/counters, a six10 vector two-level interrupt architecture, a full duplex serial port, on-chip oscillator, and clock circuitry. In addition, the AT89C52 is designed with static logic for operation down to zero frequency and supports two software selectable power saving modes.

The Idle Mode stops the CPU while allowing the RAM, timer/counters, serial port, and interrupt system to continue functioning. The Power-down mode saves the RAM contents but freezes the oscillator, disabling all other chip functions until the next interrupt.

4.2 Oil Level Sensor:

The Rxl oil level sensor are best suited to oil level measurement and the oil mainly used in generator for purpose of using cooling of generator .When temperature of generator goes high, oil level in generator tank decreases due to heating effect .For normal operation of generator oil level should maintain at required level. If oil level decrease beyond required level, it affect cooling generator.

4.3 Temperature Sensor:

The Thermocouples are best suited to very low and very high temperature measurements. The typical measuring range is from $-270\text{ }^{\circ}\text{C}$ to $+2600\text{ }^{\circ}\text{C}$. In addition, thermocouples are low-cost, very robust. The temperature sensor which is used to monitoring the generator temperature and when the generator temperature exceeds predefined limits it is known through temperature sensor. The choice of a sensor depends on the accuracy, the temperature range, speed of response, thermal coupling, the environment (Chemical, electrical, or physical) and the cost.

4.4 Fuel Level Sensor:

PH606 liquid level sensor measures different kinds of liquid level by utilizing capacitive technology. The fuel level sensor using to monitoring the fuel level of generator. The generator to maintain the level of fuel and an abnormal decrease in content could indicate fuel is being stolen. With a remote monitoring system that supports alarms, a notification is sent immediately when the theft occurs. Even if it's difficult to catch the thieves, you're at least aware of the situation and can schedule a refill to ensure the

generators have the fuel needed to operate. In cases where organized theft is common, awareness of the tank's fuel level might help you detect patterns and take action.

4.5 GSM Modem:

The SIM300 is a complete Tri-band GSM solution in a compact plug-in module. The Featuring an industry-standard interface, the SIM300 delivers GSM/GPRS900/1800/1900Mhz performance for voice, SMS, data and Fax in a small form factor and with low power consumption. The leading features of SIM300 make it deal fir virtually unlimited application, such as WLL applications (Fixed Cellular Terminal), M2M application, handheld devices and much more .This GSM Modem can accept any GSM network operator SIM card and act just like a mobile phone with its own unique phone number.

Advantage of using this modem will be that you can use its RS232 port to communicate and develop embedded applications. Applications like SMS Control, data transfer, remote control and logging can be developed easily. The modem can either be connected to PC serial port directly or to any microcontroller. It can be used to send and receive SMS or make/receive voice calls. It can also be used in GPRS mode to connect to internet and do many applications for data logging and control. In GPRS mode you can also connect to any remote FTP server and upload files for data logging. This GSM modem is a highly flexible plug and play quad band GSM modem for direct and easy integration to RS232 applications. Supports features like Voice, SMS, Data/Fax, GPRS and integrated TCP/IP stack.

5. Software Implementation

The proposed system has implemented LabVIEW which stands for Laboratory Virtual Instrumentation Engineering Workbench, is a graphical computing environment for instrumentation, system design, and signal processing. In my project using Lab view is very easiest and more powerful tools for acquiring, analyzing and presenting real word date.

By using LabVIEW to prototype, design, test, and implement our instrument systems, it can reduce system development time and increase productivity using LabVIEW, can create 8-bit compiled applications that give you the fast execution speeds needed for custom data acquisition, test, Measurement, and control solutions and also can create stand-alone executable mode of function.

5.1 Flow Chart

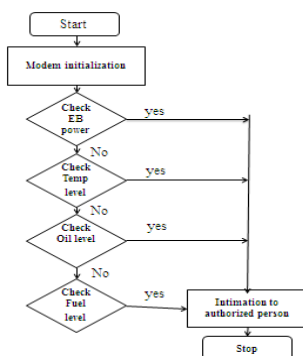

Figure 3. Flow Chart

5.2 Algorithm

- Step 1: Start the program
- Step 2: To initialize the system
- Step 3: Get Hardware Software for relevant application.
- Step 4: To monitoring the generator status and parameter and if any abnormal conditions occur it is automatically intimated to authorized person.
- Step 5: If new SMS received on mobile and go to step3 else, go to step1
- Step 6: Receive SMS
- Step 7: Check SMS pattern
- Step 8: Control the device based on status and operator can making a decision.
- Step 9: Notify end user
- Step 10: Go to step1

6. Result

We need to monitor temperature range and fuel, oil level and circuit breaker status of generator.

Under normal condition

Temperature Range : 100 degree

Fuel Level : 1000 Liter

Oil Level : 4 Liter

Taking the data of previous fault condition and intimated automatically when they exist their limit. Regarding taking threshold value, we have to take account the normal fuel, temperature, oil of generator and associated errors. The simulation to be taken by using LabVIEW software.

Block diagram:

Front panel:

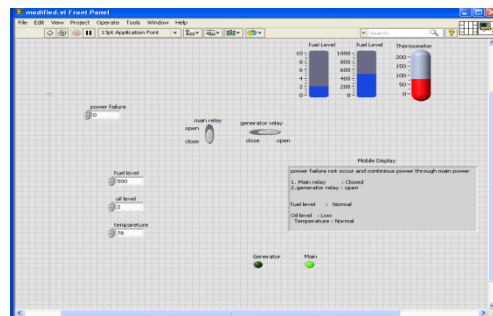
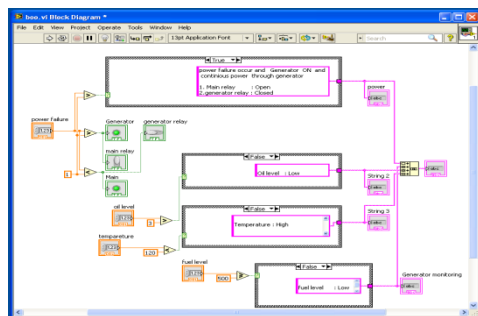

Figure 4. Block Diagram of Simulation Model

Figure 5. Continous Power through Generator Status

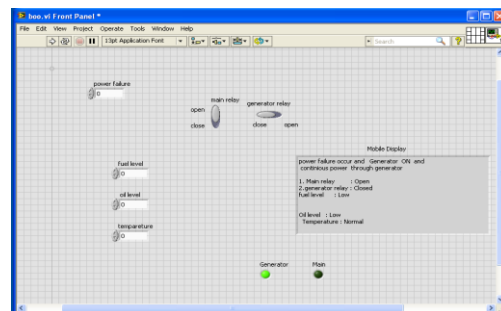
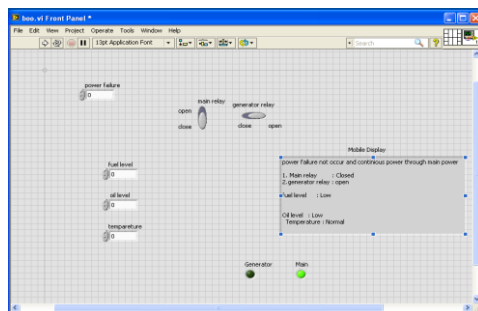

Fig 6: Continous Power through Main Status

Fig 7: Generator Parameter Status

7. Conclusion

As steel manufacturing extends from ore handling to tracking wagon movement carrying finished steel, operations are complex and there is no single control system deployed to control the entire integrated plant. In particular the suggested system will be a powerful, flexible and secure tool that will offer this service at any time, and from anywhere with the constraints of the technologies being applied. However, the GSM system poses some potential threats. But the suggested system can be used as a reference or as a base for realizing a scheme to be implemented in other projects of greater level. Further it is hoped that it will serve as a basis for further study of industrial power management strategies and The GSM based monitoring of generator is quite useful as compared to manual monitoring and also it is reliable as it is not possible to monitor always the oil level, temperature rise, manually.

After receiving of message of any abnormality we can take action immediately to prevent any catastrophic failures of generator. We need not have to check generator status and thus we can recover the system in less time. The time for receiving messages may vary due to the public GSM network traffic but still then it is effective than manual monitoring..

References

- [1] A. Sachan, "Microcontroller based Based Substation Monitoring and Control System with Gsm Modem" IOSR Journal of Electrical and Electronics Engineering, vol. 1, no. 6, (2012).
- [2] M. Sarsamba "The Load Monitoring and Protection on Electricity Power lines using GSM Network", International Journal of Advanced Research in Computer Science and Software Engineering, vol. 3, no. 9, (2013).
- [3] S.Vimalraj, R.B. Gausalya, "GSM Based Controlled Switching Circuit between Supply Mains and Captive Power Plant", International Journal of Computational Engineering Research, vol. 03, no. 4, (2013).
- [4] A. Palamar "Control System for a Diesel Generator and UPS Based Microgrid", Scientific Journal of Riga Technical University Power and Electrical Engineering, vol. 27, (2010).
- [5] K. S. Ahn "Digital Controller of a Diesel Generator using an Embedded System" International Journal of Information Processing Systems, vol.2, no. 3, (2006).
- [6] H. Arleving, "Ways to cut power generator maintenance" the journal, (2013).
- [7] C. Patil, C. Baligar, "Base Transceiver Station (BTS) Safety and Fault Management", International Journal of Innovative Technology and Exploring Engineering, vol. 3, no. 7, (2013).
- [8] Y. Jaganmohan Reddy, Y. V. Pavan Kumar, K. Padma Raju, A. Ramsesh, "PLC Based Energy Management and Control Design for an Alternative Energy Power System with Improved Power Quality", International Journal of Engineering Research and Applications, vol. 3, no. 3, (2013).
- [9] A. T. Alan "A Field Study of Human-Agent Interaction for Electricity Tariff Switching", Agents, Interaction and Complexity Group, University of Southampton.
- [10] J. Pierce and E. Paulos, "Beyond energy monitors: interaction, energy, and emerging energy systems", Proc. CHI'12. ACM, (2012).

Authors



S.Boopathi is pursuing, PG in the discipline of Embedded System Technologies at Knowledge Institute of Technology, Salem, under Anna University, Chennai, India. He received his UG degree in the discipline of Electrical and electronics engineering in CMS collage of Engineering at Namakkal under Anna University, Coimbatore, India .He has published and presented a number of technical papers in Technical symposiums and he got best project award in project event national level. He is an Executive member of Embedded Club in Knowledge Institute of Technology at Salem.



M.Jagadeeshraja is currently working as an Assistant Professor in the Department of Electrical and Electronics Engineering at Knowledge Institute of Technology, Salem. He received his B.E. - Electrical and Electronics Engineering Degree from Paavai Engineering College under Anna University, Chennai and M.E. – Embedded System Technologies form Academic Campus, Anna University of Technology, Coimbatore. He has published and presented number of technical papers in National and International conferences. He is guiding number of projects for UG and PG students.



Mr.L.MANIVANNAN is currently working as an Assistant Professor in the Department of Electrical and Electronics Engineering at Knowledge Institute of Technology, Salem, Tamilnadu. He received his UG degree in the discipline of Electrical and Electronics Engineering from Institute of Road and Transport Technology under Anna University, Chennai and PG degree in the discipline of Power Electronics and Drives from K.S.R. College of Engineering under Anna University of Technology, Coimbatore. He presented technical papers at National and International level conferences. His research interests lie in the field of Power Electronics, Renewable Energy, and Embedded Systems.



M.Dhanasu is currently working as an Assistant General Manager in the Department of Electrical at, Salem Steel Plant. He received his B.E. - Electrical and Electronics Engineering Degree from Government Engineering College under Anna University, Chennai and M.E. – Applied Electronics Government engineering College, under Anna University of Technology, Salem. His research includes in Embedded System, Re-winding of distribution transformer, industrial Drives and control, PLC, SCADA for power system. He has published and presented number of technical papers in National and International conferences. He is guiding number of projects for UG and PG students.