

Optical Inspection of Laser Markings in the Production Process

Christian Teutsch, Dirk Berndt,
Jost Schnee
*Fraunhofer Institute for Factory
Operation and Automation (IFF),
Magdeburg, Germany*
christian.teutsch@iff.fraunhofer.de

Matthias Hübner,
Norbert Bachfischer
*Siemens AG, Industry Sector,
IA CD CC FTQ 31
Amberg, Germany*

Abstract

This paper presents a novel method for the objective quality evaluation of letterings at the example of laser markings. The proposed method enables an automated quality evaluation during random inspection of small quantities of frequently changing items. The markings are segmented from the image within a first step and compared against a master piece in the second step. Each character and contour is evaluated with regard to completeness, contrast, edge width and homogeneity according to quality criteria based on the human visual perception. Thus our approach provides an user-independent evaluation method with high repeatability and reproducibility for its industrial application.

Keywords: *letter quality, pattern analysis, template matching*

1. Introduction

Quality assurance has become a key instrument in the modern process of manufacturing. The field of quality evaluation of markings is still dominated by human inspection techniques. The motivation of our work is to objectify the quality evaluation of laser markings applied on plastic bodies for electric circuits to ensure a good readability. Actually, "good" is a subjective measure that varies between single persons. Our approach automates and objectifies this inspection using image processing techniques. Existing methods and measurement systems for the marking evaluation focus on specific tasks. Generally, variances between a golden sample and the current specimen are analyzed. For example, [1] and [2] use neural networks and knowledge-based systems for quality evaluation while [3] compares a gray scale card against the current sample to evaluate the contrast. These methods are optimized for high clock frequencies and OK/NOK classifications of infrequently changing items. Compared to inspection systems humans have a larger dynamic range but lack the objectiveness of automated systems and do not achieve their high repeatability and reproducibility.

The purpose of our measurement system is to evaluate the marking quality in order to control and optimize the laser marking process according to the human visual perception. To allow rapid changes in the product appearance a high flexibility is required as well. The considered markings are brought on ten materials with five different colors. The variety of the marking patterns is larger than one thousand, each of them consisting of several characters, symbols and contours. Thus, our approach avoids learning steps as it would be required for knowledge-based methods. It takes advantage of the fact that the master marking is stored as a vector graphic, which is used as a reference without teaching the system or searching for a

faultless golden sample. The evaluation method includes completeness, contrast, edge width and homogeneity.

In order to identify the contours the master marking is aligned with the marking on the specimen first. Thereto a Canny edge detector [4] is deployed for segmentation. The mapping between the coordinates of the master marking and those of the examined marking uses an iterative closest point (ICP) algorithm [5] based on Horn's method to find a closed-form solution of absolute orientation [6]. The characteristic of the examined specimen allow for a histogram based peak-and-valley element segmentation algorithm comparable with the Gaussian smoothing procedure from Tsai [7]. Homogeneity measures are derived from co-occurrence matrices according to [8].

The optical resolution limit or point spread function of the human eye is 30 seconds of arc, and corresponds to the spacing of receptor cells on the fovea [9]. Therefore the theoretical minimum separable of a sinusoidal pattern is 60 periods per degree. This equates to a visus of 2.0 [10] which is never reached in reality. At a visus of 2.0 the minimum separable at a distance of 0.35m is approximately 0.1mm. Taking image sampling into account we chose a resolution for the camera system of 0.05mm per pixel. Furthermore, the optical resolution limit of the human eye depends on the contrast. Thus the minimum separable declines with descending contrast.

2. Marking evaluation

In the following section we discuss a new method applied for objective quality evaluation of markings. In the first paragraph the marking selection and the template matching procedures are presented. Afterwards we propose a new method for distortion correction, which is needed to handle influences from optical systems. Finally a comparative study evaluates the results from a poll about human visual perception with the objective measures in the last paragraphs.

2.1. Marking segmentation and template matching

The precondition for the evaluation is to segment the markings in the camera image and to align them with the given reference contours of the master markings supplied by the user. This is performed with a multistage approach as shown in Figure 1.

First, the contours of the master markings and those of the specimen are found using the Canny edge detector which yields connected edge segments. These data is segmented by applying a region growing algorithm.

Second, the vector contours of the master markings are extracted from the input file and (pre)aligned to the segmented markings from the camera image taken with an iterative closest point (ICP) algorithm.

Third, the master markings are finally aligned to the segmented markings with a new method for fractional template matching which reduces errors due to lens distortions. Finally each marking element is, again, segmented from its local environment.

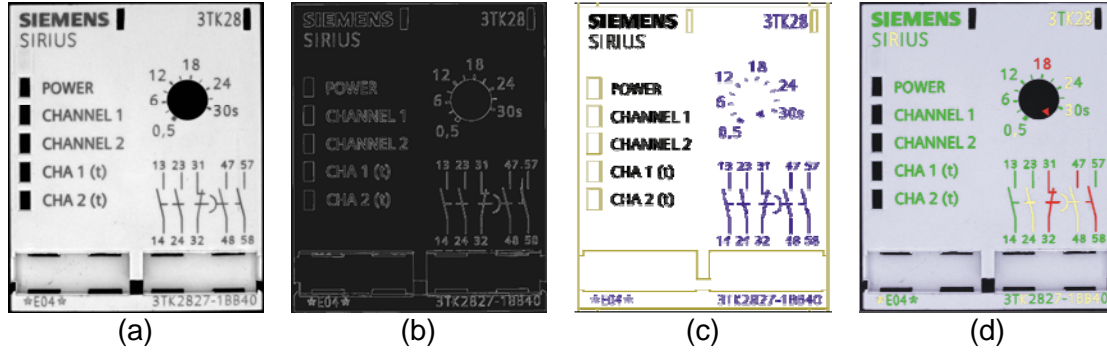

Figure 1. Segmentation of the markings (a), matching the edges (b) with a given vector graphic of the master marking (c), and final evaluation result from green (ok) to red (nok) (d).

Thereafter the translation \mathbf{t} , the rotation \mathbf{R} and the scaling s are calculated in order to map the master marking to the segmented marking. This is accomplished by an ICP algorithm supported by Kd-trees [11] with $O(n)$ median partitioning [12]. The algorithm efficiently minimizes the euclidean distance \mathbf{E} between the points of the segmented marking \mathbf{m}_i and their nearest neighbor \mathbf{d}_i from the transformed points of the master marking.

$$\mathbf{E}(\mathbf{s}, \mathbf{R}, \mathbf{t}) = \frac{1}{N} \sum_{i=1}^N \mathbf{m}_i - (\mathbf{sRd}_i + \mathbf{t})$$

To reduce the influence of lens distortions from the optical systems the master marking contours are distorted instead of undistorting the taken image. This step preserves the input quality and is more efficient since it does not require an image distortion with time-consuming interpolations. Once translation, rotation and scaling are calculated, the whole master marking is mapped to the segmented marking by applying the global transformations.

The remaining distortions are corrected by the local adjustment as shown in section 2.2. In the last step the elements on the specimen are segmented in the local area of the elements of the master marking. This performed by a binarization algorithm benefiting from the bimodal histograms of the specimen [13]. After smoothing the histogram with a Gaussian, our algorithm computes the two peaks and the valley in between. The threshold is set to the point where the histogram falls below a value of 1% of the background peak or to the minimum if this is reached before.

2.2. Distortion correction by raster alignment

There are several influences that affect the appearance of the taken image from the master. These are distortions due to the imaging and laser marking system (optical mapping through laser/camera optic, alignment of laser/camera and specimen).

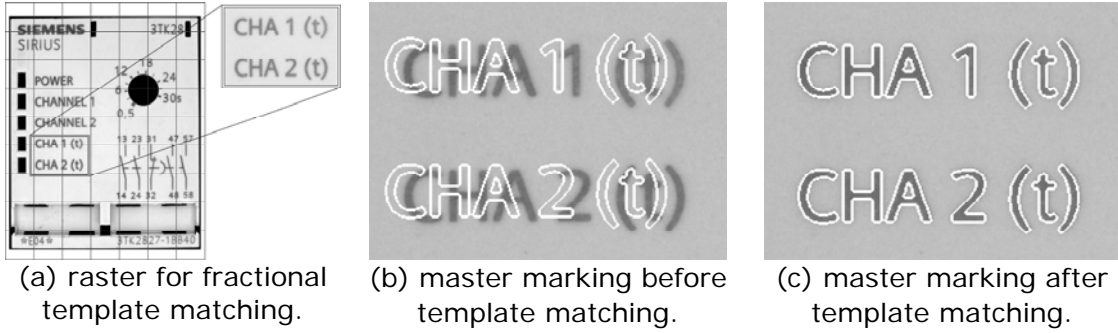

Figure 2. Raster approach for local template matching and detail at the beginning and the end of the whole matching process.

After having corrected the camera optics distortion the remaining distortions of the laser optics remain and are adjusted by a local template matching. Thereto the image is divided into sub-images in a raster of 100x100 pixels as shown in Figure 2(a) which corresponds to a representative region of 0.5x0.5mm². For every sub-image a template matching limited to translations between the equivalent part of the master marking and the segmented marking is accomplished. The translations are ordered in a grid positioned at the centers of the sub-images. The translation of every template pixel is calculated by bilinear interpolation from the translations of the adjacent grid positions. Compared to image correction based on the camera system this approach benefits from being able to adjust distortions due to the laser marking system without affecting the image quality as shown in Figure 2(b)(c).

2.3. Poll about human perception

To ensure the results of the inquest about human perception a poll was accomplished. In this poll 15 test persons were interviewed twice. They had to evaluate four multiplied by ten specimen out of 4 different materials, which showed five markings in five different sizes and qualities. All test persons had to grade every marking into OK/partly OK/NOK respecting contrast, edge width (sharpness) and homogeneity. The analysis of the poll showed the following facts: There are strong correlations in the evaluations of specimen with good and bad quality but the evaluations of specimen with medium quality showed a lot of differences. For the overall impression contrast is more important than edge width (sharpness) and homogeneity. Furthermore, bigger markings (2.8mm) are graded better than smaller ones (1.0mm) and textures with a period length smaller than 0.2mm do not affect the perception of homogeneity.

These facts show that humans generally have a good visual perception even for small differences, but each test person has its own threshold to distinguish between good, medium and bad quality. Furthermore minimum size and minimum contrast are most important. Although there was a certain variance between the subjective quality evaluations we could derive borders which were mapped to thresholds discussed in the following section.

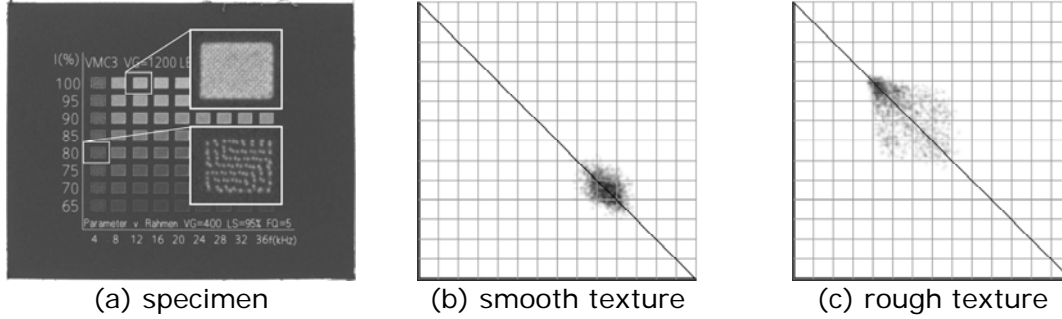

Figure 3. Specimen and the different value distributions within the co-occurrence matrices for smooth and rough textured regions.

2.4. Evaluation methods

First the completeness of each object is computed by comparison with its equivalent in the master markings. If the completeness of one object does not reach the threshold it is discarded. Otherwise it is merged with its equivalent in the master markings to build a perfectly shaped model for the next calculations.

Afterwards, Michelson contrast C of every object is derived from the intensities I_{max} and I_{min} of foreground and background [14]. Subsequently the edge width E is calculated from the intensity difference I of each object and the average gradient magnitude along the object edges G .

$$C = (I_{max} - I_{min}) / (I_{max} + I_{min}), \quad I = I_{max} - I_{min}$$

At last the homogeneity is calculated from four different criteria. These are covariance and contrast out of co-occurrence matrices, standard deviation and maximum intensity difference. The maximum intensity difference D is the difference between the average of the 100 highest intensity values I_{high} and the average of the 100 lowest intensity values I_{low} of the object normalized with the intensity difference I of object and background.

$$E = I/G, \quad D = (I_{high} - I_{low})/I$$

The co-occurrence matrices M consist of the occurrences $P_{x,y}$ of all intensity differences between adjacent points x and y along the coordinate axes and represent textures as shown in Figure 3. The covariance COV along one axis a is derived from the differences to the local mean and normalized with the sum of the occurrences of all intensity differences p .

$$COV = \frac{1}{p} \sum_{x=0}^{255} \sum_{y=0}^{255} (x - \bar{x})(y - \bar{y}) P_{x,y} \quad COV = \sum_{\alpha=0}^1 COV^{\alpha} \frac{p^{\alpha}}{\sum_{\alpha=0}^1 p^{\alpha}}$$

The local contrast C_L along one axis is calculated by the intensity difference between adjacent points and normalized with p .

$$C_L = \frac{1}{p} \sum_{x=0}^{255} \sum_{y=0}^{255} |x - y| P_{x,y} \quad C_L = \sum_{\alpha=0}^1 C_L^{\alpha} \frac{p^{\alpha}}{\sum_{\alpha=0}^1 p^{\alpha}}$$

3. System construction

To achieve a high repeatability and reproducibility a measuring system with constant characteristics was needed. Since the measuring system is based on a camera, the scene illumination is crucial. The main component is a hemispherical dome with a circular fluorescent lamp, an aperture and a circular opening for the camera at the crest. It ensures a homogeneous lighting and, thus, makes the measurement independent from external influences. The aperture prevents the object from being hit by light rays directly.

In order to handle different objects and heights an additional vertical positioning system with a controllable translatory stage has been integrated. It ensures the correct height above the specimen, which is necessary because of the small depth of field of 5mm and to ensure the accurate ex ante scale of the master marking. The positioning step is additionally supported by showing the contours and the marking of the specimen on the display of the measurement software.

4. Verification

In order to introduce the system to the production process a Gage R&R analysis had to be performed. Therefore, we have verified the complete system and the proposed evaluation procedure with a set of 45 different test items, which have been previously classified by humans. To use the measuring system for OK/partly OK/NOK classification in the practical application, thresholds for the evaluation criteria according to the results of the survey about human perception have been ascertained (see Table 1). The feasibility of these thresholds was verified by comparative tests between human quality inspectors and the measuring system. For these tests the specimen used for the survey and other specimen from the same materials (marked with the same laser parameters) were used. The correlation of the results was higher than 90% as shown in Table 2.

In order to determine the repeatability and reproducibility of the measuring system two test series were accomplished. The standard deviations (σ) were less than 5% of the mean value as shown Table 3. The results in Table 4 show the high repeatability and reproducibility which was needed to successfully pass the verification procedure.

Table 1. Thresholds for OK/partly OK/NOK classification of ti-gray specimen.

class	completeness in %	contrast	edge width in mm	Homogeneity			
				co-variance	contrast	max. diff.	σ
OK	>90	>0.25	<0.1	<100	<10	<0.9	<12
partly OK	80-90	0.18-0.25	0.1-0.15	100-220	10-14	0.9-1.2	12-18
NOK	<80	<0.18	>0.15	>220	>14	>1.2	>18

Table 2. Correlation between the mean evaluations of the survey about human perception and the results of the measuring system.

Quality classification	Ti-gray	Pale gray	Yellow
OK	94.926	89.793	92.175
Partly OK	87.038	86.305	89.259
NOK	93.084	90.372	91.583

Table 3. Results of 25 measurements of a ti-gray specimen to compute the repeatability by using σ . The specimen has been re-positioned between the measurements.

evaluation criteria	mean	σ	σ /mean in ‰
completeness in %	99.998	0.047	0.470
contrast	0.375	0.003	8.00
edge width in mm	0.084	0.001	11.905
local covariance	32.478	1.363	41.967
local contrast	4.656	0.108	23.196
standard deviation	7.188	0.133	18.503
maximum difference	0.529	0.009	17.013

Table 4. Results of three times three measures of 10 specimen to collect the repeatability and reproducibility. The measures were performed triple by three persons.

evaluation criteria	person 1		person 2		person 3	
	mean	range	mean	range	mean	range
completeness in %	99.845	0.164	99.793	0.187	99.906	0.158
contrast	0.371	0.006	0.369	0.008	0.372	0.005
edge width in mm	0.093	0.004	0.092	0.004	0.087	0.006
local covariance	34.651	2.459	34.527	2.574	34.782	2.628
local contrast	5.048	0.184	4.983	0.198	5.179	0.212
standard deviation	7.863	0.265	7.738	0.300	8.073	0.309
maximum difference	0.627	0.023	0.664	0.035	0.668	0.031

5. Conclusion

We have presented a new method for objective quality evaluation of laser markings on plastic items. This method utilizes a template comparison of the markings which are to be evaluated only. The areas preset by the template are positioned via a two step ICP algorithm before the evaluation is accomplished. The chosen evaluation criteria completeness, contrast, edge width and homogeneity have been related to the human visual perception. To ensure a homogeneous lighting a measure dome that causes diffuse light and that is independent from external influences was built. In this work we have shown the high repeatability and reproducibility of the measuring system as well. Its ability to switch between different markings and to evaluate new markings without delay, as required when producing small quantities of frequently changing goods, makes it most useful for industrial applications.

References

- [1] Petry, J., Picard, L.: Mark quality inspection apparatus and method. US5859923. Cognex Corporation, Natick (1999)
- [2] Szatmari, I., Zarandy, A.: High-speed label inspection system for textile industry. In: IMEKO TC10 Technical Diagnostics. 10th International Conference on. Volume 1., Budapest (2005) 99-106
- [3] Peng, S.: Contrast measurement system for laser marks. US5969374. Hewlett-Packard Company, Palo Alto (1999)
- [4] Canny, J.: A computational approach to edge detection. IEEE Transactions on Pattern Analysis and Machine Intelligence (PAMI) 8 (1986) 679-698
- [5] Besl, P., McKay, N.: A method for registration of 3-d shapes. IEEE Transactions on Pattern Analysis and Machine Intelligence (PAMI) 14 (1992) 239-256
- [6] Horn, B.K.P., Hilden, H.M., Negahdaripour, S.: Closed-form solution of absolute orientation using orthonormal matrices. Journal of the Optical Society of America 5 (1988) 1127-1135
- [7] Tsai, D.: A fast thresholding selection procedure for multimodal and unimodal histograms. Pattern Recognition Letters 16 (1995) 653-666
- [8] Pietikäinen, M., Ojala, T., Xu, Z.: Rotation-invariant texture classification using feature distributions. Pattern Recognition Letters 33 (2000) 43-52
- [9] Mallot, H.: Computational Vision. Information Processing in Perception and Visual Behavior. 2nd edn. The MIT Press, Cambridge London (2000)
- [10] Graef, M.: Objektive pruefung der sehschaerfe. Zeitschrift der Ophthalmologie 97 (2000) 582-600
- [11] Nuechter, A., Lingemann, K., Hertzberg, J.: Cached k-d tree search for icp algorithms. In: 3-D Digital Imaging and Modeling. 6th International Conference on. Volume 1., Montreal (2007) 419-426
- [12] Press, W.H., Teukolsky, S.A., Vetterling, W.T., Flannery, B.P.: Numerical Recipes in C++: The Art of Scientific Computing. 2nd edn. Cambridge University Press, Cambridge (2002)
- [13] Rosin, P.L.: Unimodal thresholding. Pattern Recognition 34(11) (2001) 2083-2096
- [14] Michelson, A.: Studies in Optics. Univ. of Chicago Press (1927)

Authors



Christian Teutsch. He is a software engineer and project manager at the Fraunhofer Institute for Factory Operation and Automation (IFF) Magdeburg. In 2003 he finished his studies on Computational Visualistics at the Otto-von-Guericke University of Magdeburg. His core competencies are 2D and 3D data processing for optical measurement systems. In 2007 he got a Ph.D. in civil engineering for his research about 3D scan data analysis.



Dirk Berndt. He is the head of the Business Unit of Measuring and Testing Technologies of the Fraunhofer Institute for Factory Operation and Automation (IFF) Magdeburg. He holds a degree in electrical engineering, specialized in optics, sensors, electronics and precision mechanics of the Technical University of Ilmenau. His core competencies are image processing and optical 3D metrology. Since 2008 he holds a Ph.D. in civil engineering.



Jost Schnee. He is a software engineer at the Fraunhofer Institute for Factory Operation and Automation (IFF) Magdeburg. In 2007 he finished his studies on computational engineering with a specialization on image processing, metrology, software engineering and neuroinformatics at the Technical University of Ilmenau. His core competencies are image processing and optical 3D metrology.

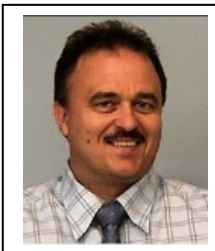

Norbert Bachfischer. He is the head of the Technology Plant Unit FTQ31 at the Siemens factory Amberg (GWA). He is in responsibility for Packing and Marking of the I IA CE CC products. In 1982 he finished his studies on electrical engineering and was responsible for the technical processes of the first Siemens CIM-factory. His core competencies are project management in logistical and manufacturing ambit including the securing of the process reliability.



Matthias Hübner. He is technology planer of product marking at the Siemens factory Amberg (GWA). In 1998 he finished his studies on Mechanical Engineering at the college of higher education Magdeburg (FH). His core competencies are project management in laser marking and inkjet marking of plastic items. Furthermore, he is specialized in 2D-Datamatrix code marking and their traceability.