

Design and Implementation of Pulse Signal Detection System Based on Bluetooth Transmission

Qingchao Gong, Guangming Li, Peng Sun and Yong Pang

¹*School of Mechanical, Electrical and Information Engineering,
Shandong University, Weihai, 264209, China
gongqchao@163.com, gmlisdu@sdu.edu.cn, 942341860@qq.com,
student0281@gmail.com*

Abstract

In order to achieve convenient and rapid detection of pulse signal, a real-time detection system of photoelectric pulse signal based on Bluetooth transmission is proposed in this paper. The system mainly includes pulse sensor, Arduino processor board, Bluetooth modules and PC management platform. The pulse signal collected by pulse sensor will be sent to Arduino processor board after being filtered and amplified. Then Arduino processor board will conduct A/D conversion and data processing on pulse signal. Thus pulse rate and time between heartbeats can be calculated, transmitted and displayed in real-time on PC management platform which is written by Processing Language. The results of the system test show that the pulse signal detection system implemented above can be served as practical application reliably.

Keywords: *pulse signal detection; Bluetooth; Arduino; PC management platform*

1. Introduction

With the rapid development of technology and the improvement of living standards, more and more people begin to pay attention to their own health. In human cardiovascular system, the pulse signal reflects the changes of arterial pressure in the combined effect of heart and arterial system, and is directly related to human physical health. Therefore the analysis of pulse signal has an important significance of monitoring the health status of a human being [1]. Advancements in sensor technology, wireless communication technology, and information technology in general give opportunities to new method for detecting pulse signal.

Pulse signal detectors traditionally were wired, in which people were difficult to freely move, because of fixed sensor equipments. Various cables would be easy to make patients nervous, which might result in inaccurate measurements. Bluetooth technology can be a good solution for this problem [2]. In this paper, a pulse signal detection system based on wireless Bluetooth transmission is proposed, which can acquire pulse signal from wireless terminal carried on the body and avoid the cable restriction and poor scalability of wired system. The system consists of a pulse sensor, Arduino processor board, and Bluetooth modules. What's more, there is a management platform on PC, through which we can easily detect and monitor the pulse signal and do some other extensions.

The remainder of this paper is organized as follows. The overall structure design of pulse signal detection system is studied in Section 2 in detail. Section 3 and Section 4 present hardware design and software design of the pulse signal detection system respectively. Finally, experimental results and extension on the proposed design are presented in Section 5, and conclusions are drawn in Section 6.

2. Design of Pulse Signal Detection System

In the view of function, pulse signal detection system can be divided into three parts: acquisition module, transmission module and PC management platform. Acquisition module can collect and process pulse signal in real time, which includes a pulse sensor and Arduino processor board. With the feeble and noisy pulse signal, a filter circuit and an amplifier circuit is needed in pulse sensor. The structure of a pulse sensor is showed in Figure 1. Arduino processor board can acquire pulse signal, then do A/D conversion and data processing. Transmission module is composed of Bluetooth sender, Bluetooth receiver and a TTL to USB converter. PC management platform based on Processing Language can display and storage related information [3]. The structure of a pulse signal detection system is showed in Figure 2.



Figure 1. The Structure of A Pulse Sensor

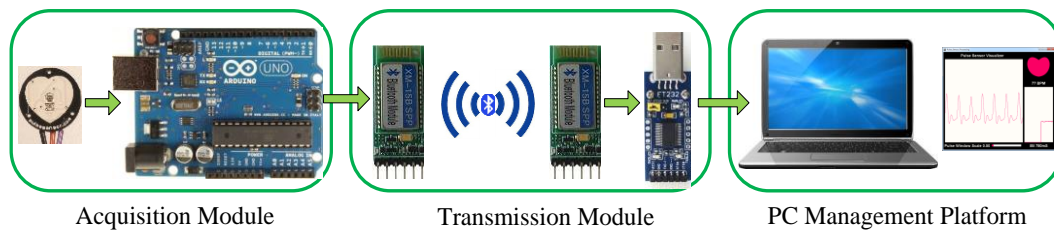

Figure 2. The Structure of A Pulse Signal Detection System

In recent years, there has been increasing interest in wearable health monitoring devices both in research and industry. The sensor in this paper is small, light-weight, flexible and capable of long-term detecting, all of which make it also be particularly suitable for wearable applications [4]. The pulse sensor, Arduino processor board and Bluetooth sender can be worn on the body. Figure 3 shows the appearance of wearing the laboratory prototype of the pulse signal detection system.

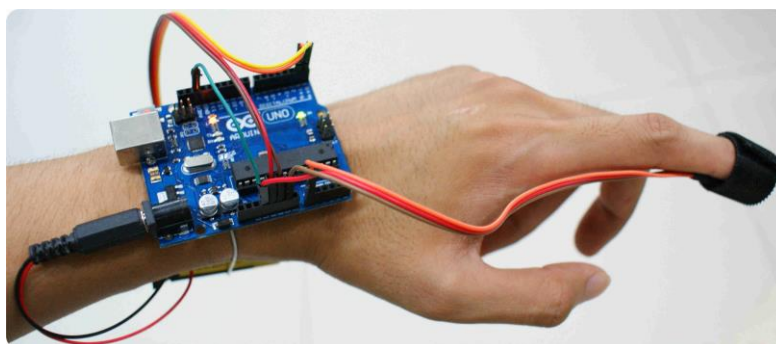

Figure 3. Appearance of Wearing the Laboratory Prototype of the Pulse Signal Detection System

3. Hardware Design of the System

Hardware design of the system focuses mainly on acquisition module and transmission module, which include pulse sensor, Arduino processor board, Bluetooth modules, and TTL to USB converter.

3.1. Hardware Design of Pulse Sensor

Photoplethysmography (PPG) is an effective way for measuring pulse signals, which provides strong technical support for clinical diagnosis. The basic principle of PPG is that the pulse measurement makes use of the different light transmittance of body tissues when blood vessels pulse. The sensor in PPG is composed of light source and photoelectric transformer, which can be fixed on patients' finger or earlobe by Velcro tapes or clips. Light source commonly choose light emitting diode with a certain wavelength which is selective for oxygen and hemoglobin in arterial blood. When the light beam passes through human body peripheral vessels, light transmittance will vary with the change of blood volume for arterial pulse. At this moment, photoelectric transformer receives the light reflected by body tissue, and converts it into electrical signal. After that, electrical signal will be amplified and output [5]. Since pulse and arterial vessel volume is periodic changed because of heart beat, thus the change cycle of electrical signal is pulse rate.

The light source in this paper uses a green LED with the peak wavelength of 515 nm, which belongs to model AM2520. While the photoelectric transformer uses APDS-9008, which is an environment photoreceptor with the peak wavelength of 565 nm. The sensor has a high sensitivity on account of the similar peak wavelength of light source and photoelectric transformer. Further, since frequency band of the pulse signal is generally between 0.05~200 Hz, and signal amplitude is very small, which usually in millivolt level. Pulse signal is susceptible to various disturbances. Due to a low pass filter and amplifier constituted by MCP6001 behind the photoreceptor, electrical signal can be amplified 331 times. Figure 4 shows the pulse sensor circuit diagram.

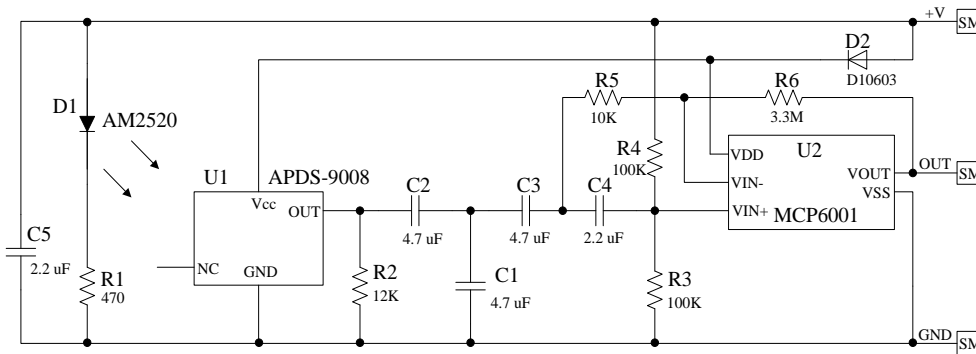

Figure 4. Pulse Sensor Circuit Diagram

3.2. Hardware Design of Arduino Board

In this paper, we use Arduino Uno R3 as the core control board which can coordinate the work of each module and process the relevant data [6]. The Arduino Uno R3 is a microcontroller board based on ATmega328. It has 14 digital input/output pins (of which 6 can be used as PWM outputs), 6 analog inputs, a 16 MHz ceramic resonator, a USB connection, a power jack, an ICSP header, and a reset button. The ATmega328 has 32 KB flash memory (with 0.5 KB used for the boot loader). It also has 2 KB of SRAM and 1 KB of EEPROM (which can be read and written with the EEPROM library). The Uno differs from all other preceding boards in that it does not use the FTDI USB-to-serial driver chip. Instead, it features the Atmega16U2 programmed as a USB-to-serial converter. The ATmega328 also provides UART TTL serial communication, which is available on digital pins 0 (RXD) and pins 1 (TXD). Figure 5 shows ATmega328 chip application circuit.

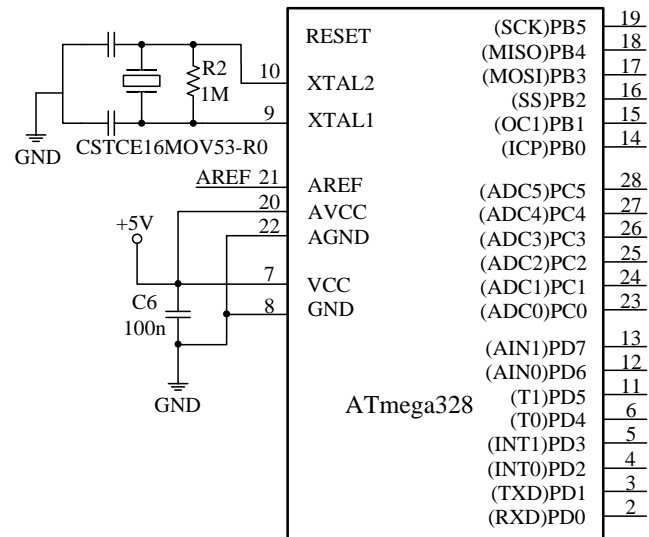

Figure 5. ATmega328 Chip Application Circuit

3.3. Hardware Design of Bluetooth Module

XM-15B Bluetooth module realizes the Bluetooth SPP specification and accords with the Bluetooth 2.1+EDR protocol standard. The module has two working modes: command mode and data mode. When working at data mode, the module can be divided into three working roles, master, slave and loopback. When working at command mode, the module can execute AT commands. Then users can send a variety of AT commands to Bluetooth module for parameter setting or control commands sending. The module will work at command mode and be ready to receive AT commands, when it is not connected to any device. In addition, when working at command mode, Bluetooth module can be connected with other Bluetooth devices or connect with other Bluetooth devices actively based on setting roles. Bluetooth module will enter data mode automatically after it connects with other Bluetooth devices [7]. XM-05 is the core module on XM-15B. Figure 6 shows the core application circuit of XM-05.

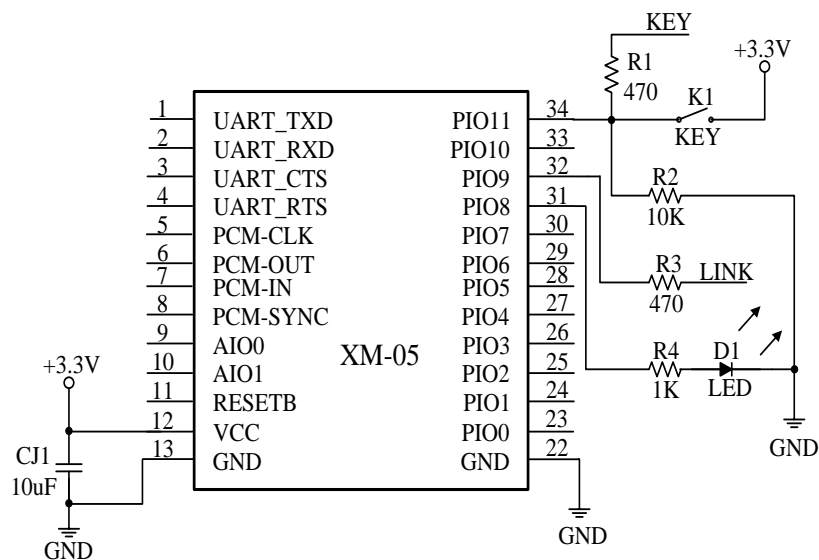

Figure 6. Core Application Circuit of XM-05

4. Software Design of the System

Software design of the system mainly focuses on program design of Arduino board, Bluetooth modules and PC management platform. Arduino board can acquire and process pulse signal, then send corresponding data to the PC management platform through Bluetooth transmission.

4.1. Software Design of Arduino Board

Arduino board is the core of the pulse signal detection system. The program design of Arduino board can be mainly divided into four parts: sampling, filtering, calculating and output. Sampling collects pulse analog signal outputted of pulse sensor by ADC unit. The sampling rate is 500 HZ, as well as the AD accuracy generally chooses 10 bit accuracy. The reason of filtering is that the dicrotic wave will be formed when pulse wave reflects in arteries. To avoid the interference of dicrotic wave, the pulse rise will be tracked every 0.6 time between heartbeats in the program. Then time between heartbeats and heart rate value will be calculated. Finally, data will be output to Bluetooth module through serial port. The workflow of Arduino board is showed in Figure 7.

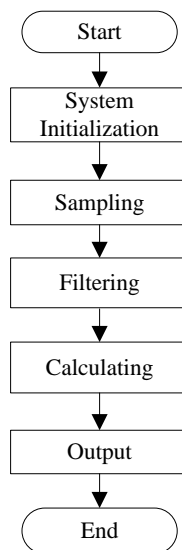

Figure 7. Workflow of Arduino Board

4.2. Software Design of Bluetooth Module

Bluetooth host controller interface (HCI) is the software and hardware interface between Bluetooth module and the host in Bluetooth Host-Host Controller application mode. One module must be set as master device and another as slave device, when two Bluetooth modules communicate.

Bluetooth host and Bluetooth module implement the interaction through a variety of HCI packets. HCI packets have three types: command packet, event packet and data packet. Since the system only involves the data exchange, so data packet only includes ACL asynchronous connectionless mode. Various packets transmit according to the priority in which high byte precedes low byte. Through a series of simple HCI interface API function calls and corresponding actions execution through the judgment of space returned information, Bluetooth wireless data communication can be easily accomplished between two modules [8]. Figure 8 shows the workflow of Bluetooth module.

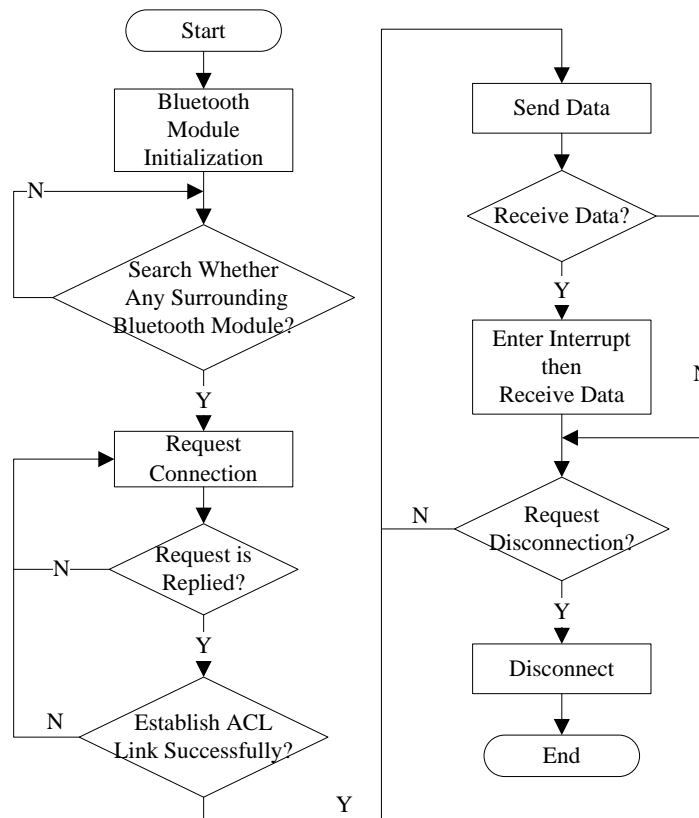

Figure 8. Workflow of Bluetooth Module

4.3. Software Design of PC Management Platform

The software design of PC management platform is based on Processing Environment. The Processing environment includes a text editor, a compiler, and a display window. It enables the creation of software within a carefully designed set of constraints [9]. PC management platform in this paper can display heart rate value, pulse waveform, time between heartbeats and heart rate curve. What's more, it can also store related data such as heart rate value and pulse waveform in PC for the work extension. Figure 9 shows a screen shot of the PC management platform.

5. System Test and Extension

A comprehensive test has been done after the completion of system software and hardware design. In order to examine accuracy and reliability of the system, we fix the pulse sensor on human's fingertip and let the subject be relaxed. Then the test results are showed in Figure 9. As we can see from it, the heart rate is 80 beats every minute, and time between heartbeats is 742 ms. Test results show that the pulse signal detection system implemented by this paper can fulfill the task successfully.

In addition, when the information displayed on the PC management platform, some related data are stored in the form of TXT on PC. We can do some further research using the related data, such as studies on other platforms or remote transmission and detection. Figure 10 shows the pulse waveform applied in MATLAB Environment.

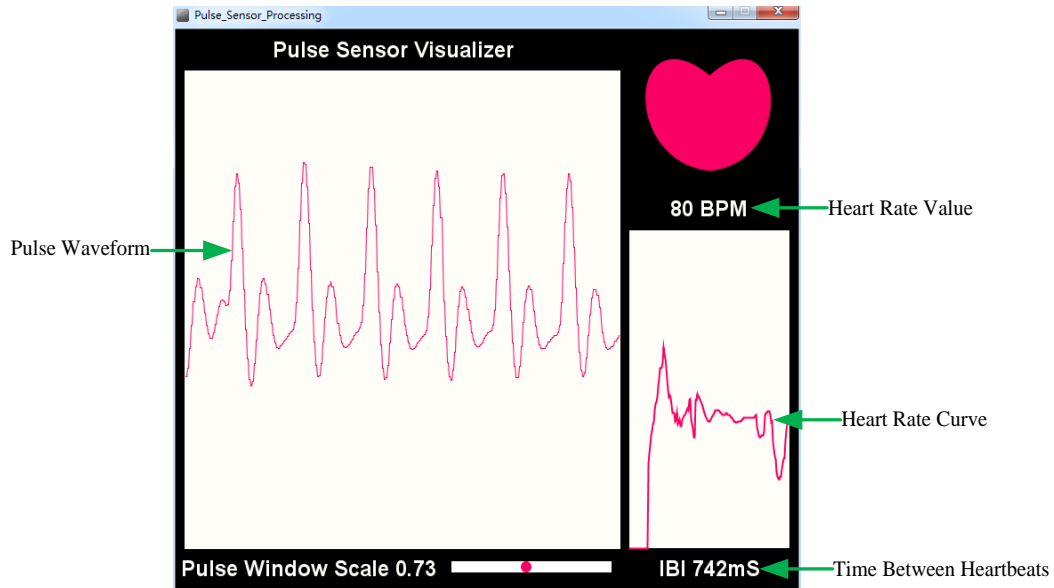

Figure 9. A Screen Shot of the PC Management Platform

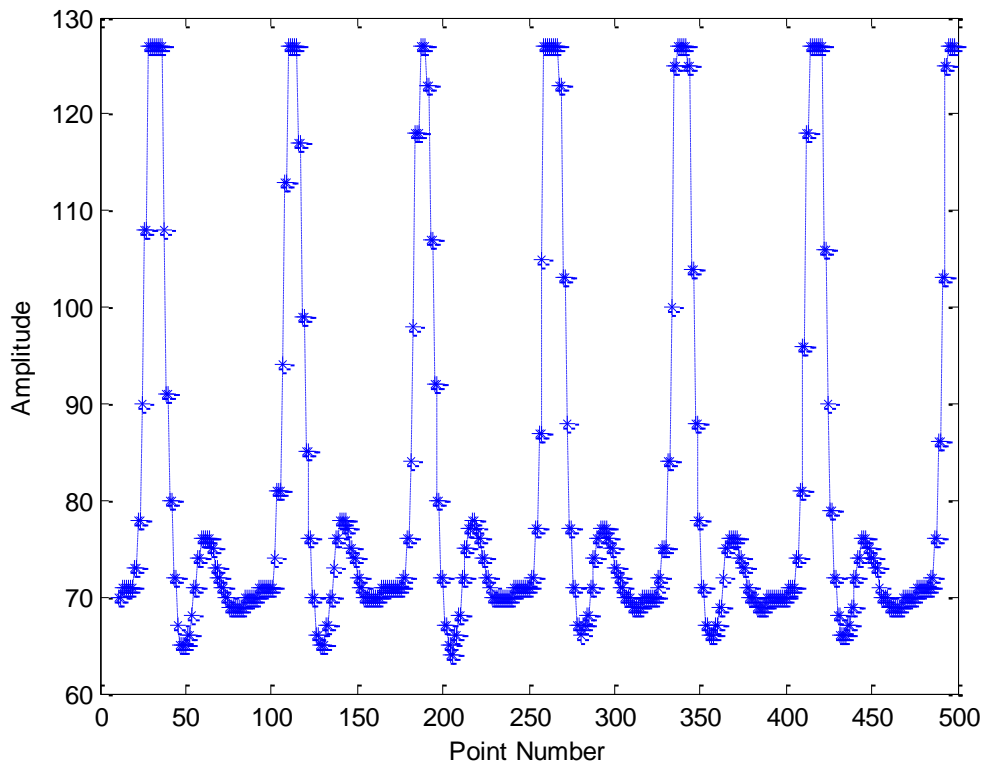

Figure 10. Pulse Waveform Applied in MATLAB Environment

6. Conclusions

The pulse signal detection system based on Bluetooth transmission is a new solution that used to meet the demand of high automation and convenient medicine. In this paper, we use Bluetooth technology to replace the intricate cables. And the system is low cost, high reliability, simple structure and free in transmission. We collect pulse signal through pulse sensor, and then send to microchip for real-time processing, calculate related data and display important information on PC management platform.

Pulse signal has large of physiological and pathological information. And pulse signal processing can make early detection and treatment of illness [10]. The pulse signal detection system has the vital significance for health monitoring of people.

Acknowledgements

This research in part was supported by Science and Technology Development Project of Shandong under Project No. 2011GSF12007. Additional support was provided by a grant from Independent Innovation Foundation of Shandong University. The authors would like to thank Dr. Zunhua Guo and Dr. Chengyou Wang for their help and valuable suggestions. The authors also thank the anonymous reviewers and the editor for their valuable comments to improve the presentation of the paper.

References

- [1] A. Zhang and H. Wang, "Real-time detection system for photoelectric pulse signals", Proceedings of International Conference on Business Management and Electronic Information, (2011); Guangzhou, China.
- [2] U. Pandya and U. Desai, "Bluetooth electrocardiogram: its evaluation in a hospital environment", IEEE Pulse, vol.4, no.3, (2013), pp.35-40.
- [3] H. Shang, Q. Zhang, M. Jin, W. Wang, J. Zhu, and Q. Kong, "A portable pulse signal acquiring and monitoring system based on Android platform", Proceedings of IEEE International Conference on Bioinformatics and Biomedicine, (2013); Shanghai, China.
- [4] J. Sun-A, L. Young-Dong, J. Do-Un, and H. Gi-Hyun, "Implementation of pulse wave monitoring system using wearable PPG measurement system in daily life", Proceedings of 7th International Conference on Computing and Convergence Technology, (2012); Seoul, Korea.
- [5] B. A. Izneid, I. Sukar, M. Ali, and M. Souiyah, "Development of wireless Bluetooth heart rate remote monitoring system", Proceedings of IET International Conference on Wireless Communications and Applications, (2012); Kuala Lumpur, Malaysia.
- [6] Banzi and Massimo, "Getting Started with Arduino", O'Reilly Media, Inc., (2009).
- [7] A. Zhang and L. Hu, "The system of pulse monitoring based on Windows Mobile", Proceedings of International Conference on Business Management and Electronic Information, (2011); Guangzhou, China.
- [8] P. S. Kumar, S. Oh, P. Rai, H. Kwon, N. Banerjee, and V. K. Varadan, "Design and implementation of a bluetooth-based band-aid pulse rate sensor", Proceedings of Nanosensors, Biosensors, and Info-Tech Sensors and Systems, (2011); San Diego, CA, United states.
- [9] Reas, Casey and Ben Fry, "Getting Started with Processing", O'Reilly Media, Inc., (2010).
- [10] I. Korhonen, J. Parkka and M. Van Gils, "Health monitoring in the home of the future", IEEE Engineering in Medicine and Biology Magazine, vol.22, no.3, (2003), pp. 66-73.