

Shifting Control and Analysis of Dual Clutch Transmission of Automobile

Xiaohui Xia

Changzhou College of Information Technology, Changzhou, Jiangsu 213164,
China
xiaohui0617@126.com

Abstract

According to the DCT structure and principle, the dynamic shifting process of DCT has been analyzed, and the engine and clutch model have been established. The driver intention has been analyzed and distinguished through the fuzzy control theory, on this basis, gear shift rule has been formulated based on driver intention, separately from the power performance and economy performance. Clutch and engine control strategy for DCT shifting process have been proposed, and shifting control logic also has been drawn up. DCT shifting simulation model has been established based on the MATLAB/Simulink software simulation platform. The simulation result shows that the shifting simulation model in this study meets the requirement, and the shifting control strategy has a good control effect.

Keywords: *automobile, dual clutch transmission; driver intention; gear shift rule; control strategy*

1. Introduction

In the automotive industry, the automatic transmission has long been regarded as a substitute for manual transmission. As a key performance indicator of automobile, the economic performance of vehicle fuels has been gradually valued, and the control strategy of automobile's automatic transmission is very important. The development trend of automatic transmission is mainly reflected in such aspects as excellent economy and comfort of driving and so on.

To select the appropriate gear through the cooperation between the intention of the driver and the controller of the vehicle, low fuel consumption can be realized in most operation cases of the engine, while the control of the transmission of the conventional automatic transmission is realized through the control of torque converter and a planetary gear set. Though after years of improvement, the efficiency of mechanical transmission is still lower than that of the manual transmission. Therefore, the primary goal of the automotive industry is to improve the mechanical efficiency, and at the same time, to ensure the comfort and high quality of automatic gearshift [1-2].

DTC (Dual Clutch Transmission) is a new type of automatic transmission device in the field of automotive automatic transmission. It realizes power transmission and interruption, and shifting without power interruption through respective connection between the two transmission shaft and two clutches. DTC also combines the advantages of manual transmission and traditional torque mechanic transmission so as to equip the vehicle with the same convenience and comfort with manual transmission vehicles, but better fuel economy [3-4]. Shift control is the key technology of DCT vehicles, and an important index to measure the driving comfort of vehicles, therefore, to carry out targeted shift analysis and control of the DCT seems quite necessary.

According to the characteristics of DCT synchronizer which can be pre-engaged in the shift, under the premise of ensuring the accurate realization of the synchronizer's function, Yang Weibin [5] put forward the control law of DCT synchronizer, achieving accurate control of synchronizer, but he did not take into account the control of clutch; Ma Jin [6] took the up shift of Block 1 to Block2 as an example to describe the DCT shift process, and put forward the control method to improve shift quality according to the clutch engaging speed and engaging time, which has obtained certain results, but has not involve the driver intention, nor economic and dynamic effects were representative; Zhao Zhiguo [7] conducted shift researches targeted at a five speed dry dual clutch transmission to discuss the torque coordinated control between the engine and DCT. Considering the characteristics of the physical structures, they established 5 degrees of freedom shifting dynamics equation, and the results showed that the proposed torque coordinated control strategy based on models reflected the driver intention of shifting, which improved the shift quality of DCT, but the control structure was relatively complex.

Aiming at a five rates wet DTC, this paper conducts dynamics analysis of the DCT shifting process and makes model and analysis of key parts; on this basis, it develops a shift schedule based on driver intention, and makes detailed analysis for gear shifting process to develop a shift control strategy; finally, based on the MATLAB/Simulink simulation platform, it builds DCT shift model and conducts simulation test to verify the validity of the shift control strategies.

2. Structure and Principle of DCT

Structure diagram of is as shown in Figure 1. The structure has 5 forward gear blocks and 1 reverse gear block, and two clutches respectively control the odd and even gear block. Similar with the traditional manual gear box structure, it includes helical cylindrical gear set and the synchronizer gear set, wherein Block 1 adopts the connection between one-way clutch and the input shaft as the constant mesh gear pair. Two clutches couples with input shaft through the transmission gear pair. Therefore, the two clutches can be engaged with the motor, by controlling the switch between the two clutches (isolating the off going clutch, and at the same time engaging the ongoing clutch), to complete the shift.

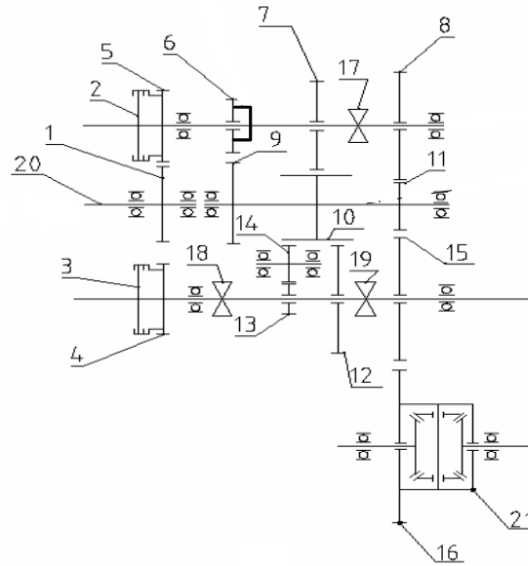

1, the main gear of the input shaft (connects to the output shaft of the engine); 2, the odd clutch; 3, the even clutch; 4, the shaft of the even clutch; 5, the shaft of the odd clutch; 6-8, the number of diver gears of the reverse gear, block 2 and block 3; 11 the driver gear of block 5; 12 the main gear of block 2; 13, the main gear of the reverse gear; 14, the falling wheel of the reverse gear; 15, the main gear of block 4; 16, the driver gear of the main decelerator; 17, the synchronizer of block 3 and block 5; 18, the synchronizer of the reverse gear; 19, the synchronizers of block 2 and block 4; 20, the input shaft; 21, the main decelerator.

Figure 1. Structure Diagram of Double Clutch Automatic Transmission

3. Dynamics Model

To establish dynamic model for transmission assembly, based on explicit understanding of the transmission route of each gear, we set up the physical model of transmission at each gear, and analyze the physical model. According to the physical model of the transmission, the dynamics model of the transmission at each gear is thus set up, and according to the relationship among transmission ratio, transmission speed and torque, the complete dynamics model of transmission is built. In the process of shifting, in order to obtain good control effect, it requires the introduction of control variables. Therefore the engine and the clutch models need to be built, too to lay foundation for the DCT shift control strategy [8].

3.1. Physical and Dynamics Model of DCT

For the convenience of establishing DCT models, the dynamic transfer system is simplified as follows: the gear is simplified as the only quality without elastic concentrated moment I_i ; the shaft is simplified without quality and only the torsional stiffness of elastic rod, the quality equivalent of each shaft section is put to the two ends of the gear; friction equivalent at the bearings is simplified as viscous damping C_i at the gear which is proportionate to transmission speed; the structural damping of the gear mesh stiffness, gear and shaft are not considered. Take Block 1 as an example, a simplified physical model and power flow line DCT is shown in Figure 2.

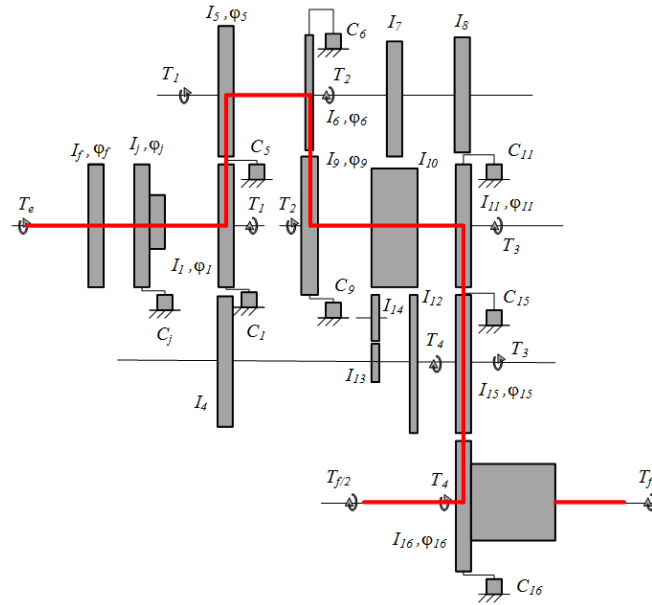

Figure 2. Dynamics Model of Double Clutch Automatic Transmission

According to the simplified physical model of DCT Block 1, the following dynamics model between the speed and torque of each shafting system is as follows[9]:

The torque of the input shaft is:

$$T_e - (I_f \ddot{\varphi}_f + I_j \ddot{\varphi}_j + I_1 \ddot{\varphi}_1 + I_4 \left(\frac{z_1}{z_4}\right)^2 \ddot{\varphi}_1) - (c_j \dot{\varphi}_j + c_1 \dot{\varphi}_1) = T_1 \quad (1)$$

The speed of the input shaft is:

$$\omega_1 = \omega_e \quad (2)$$

The torque of the Side shaft 1 is:

$$T_1 \left(\frac{z_5}{z_1}\right) - I_5 \ddot{\varphi}_5 - I_6 \ddot{\varphi}_6 - c_5 \dot{\varphi}_5 - c_6 \dot{\varphi}_6 = T_2 \quad (3)$$

The speed of the Side shaft 1 is:

$$\omega_{f1} = \left(\frac{z_1}{z_5}\right) \omega_1 \quad (4)$$

The torque of the middle shaft is:

$$T_2 \left(\frac{z_9}{z_6}\right) - (I_9 + I_{10} + I_7 \left(\frac{z_{10}}{z_7}\right)^2 + I_{12} \left(\frac{z_{10}}{z_{12}}\right)^2 + I_{14} \left(\frac{z_{10}}{z_{14}}\right)^2 + I_{13} \left(\frac{z_{14}}{z_{13}}\right)^2 \left(\frac{z_{10}}{z_{14}}\right)^2) \ddot{\varphi}_9 - (I_{11} + I_8 \left(\frac{z_{11}}{z_8}\right)^2) \ddot{\varphi}_{11} - c_9 \dot{\varphi}_9 - c_{11} \dot{\varphi}_{11} = T_3 \quad (5)$$

The speed of the middle shaft is:

$$\omega_3 = \left(\frac{z_6}{z_9}\right) \omega_{f1} \quad (6)$$

Side Shaft 2: when the even synchronizer device 19 (Figure 1) is in neutral position, torque of side shaft 2 is the friction torque on the shaft, whose speed basically maintains the speed at the finish of the shifting (If the speed is 0, the torque is 0).

The torque of idler wheel 15 is:

$$T_3 \left(\frac{z_{15}}{z_{11}} \right) - I_{15} \ddot{\varphi}_{15} - c_{15} \dot{\varphi}_{15} = T_4 \quad (7)$$

The torque of idler wheel 15 is:

$$\omega_{15} = \left(\frac{z_{11}}{z_{15}} \right) \omega_3 \quad (8)$$

The torque of block 16 driven by differential:

$$T_4 \left(\frac{z_{16}}{z_{15}} \right) - I_{16} \ddot{\varphi}_{16} - c_{16} \dot{\varphi}_{16} = T_f \quad (9)$$

The torque of block 16 driven by differential:

$$\omega_{16} = \left(\frac{z_{15}}{z_{16}} \right) \omega_{15} \quad (10)$$

Among them, T_e 、 I_f are respectively the engine output torque, the engine crankshaft (including flywheel), the output shaft and the equivalent moment of inertia of the clutch driving plate; φ_f is the angular displacement of I_f ; I_f 、 φ_f 、 c_f are respectively the equivalent moment of inertia of active part on the clutch driven plate damper, angular displacement and the viscous damping, T_1 、 T_2 、 T_3 、 T_4 、 $T_{f/2}$ are respectively the transmission torque of each component on the transmission route at block 1 power, I_1 、 I_4 、 I_5 、 I_6 、 I_7 、 I_8 、 I_9 、 I_{10} 、 I_{11} 、 I_{12} 、 I_{13} 、 I_{14} 、 I_{15} 、 I_{16} are respectively the equivalent moment of inertia of each key component of the vehicle driving system; φ_1 、 φ_5 、 φ_6 、 φ_9 、 φ_{11} 、 φ_{15} 、 φ_{16} are respectively the angular displacement of each component on the transmission route at block 1 power; and c_1 、 c_5 、 c_6 、 c_9 、 c_{11} 、 c_{15} 、 c_{16} are respectively the viscous damping of each component on the transmission route of block 1 power.

3.2. The Engine Model

The engine is a highly nonlinear system with complex operation mechanism, which is difficult to use theoretical model to describe accurately. The method of using tests can be used to get the relationship among the output torque of the engine, the solar term door opening and the engine speed. The numerical model of the engine can be obtained through repeated fitting between the output torque of the engine and speed characteristics at different degrees of opening according to experimental data, as shown in Figure 3.

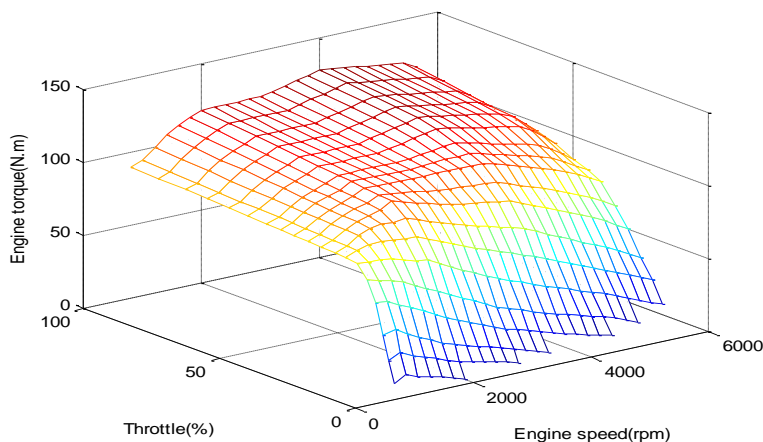

Figure 3. Engine Numerical Model

Similarly, the method of fitting experimental data with mathematics helps get the fuel consumption characteristic curve of the engine, as shown in Figure 4.

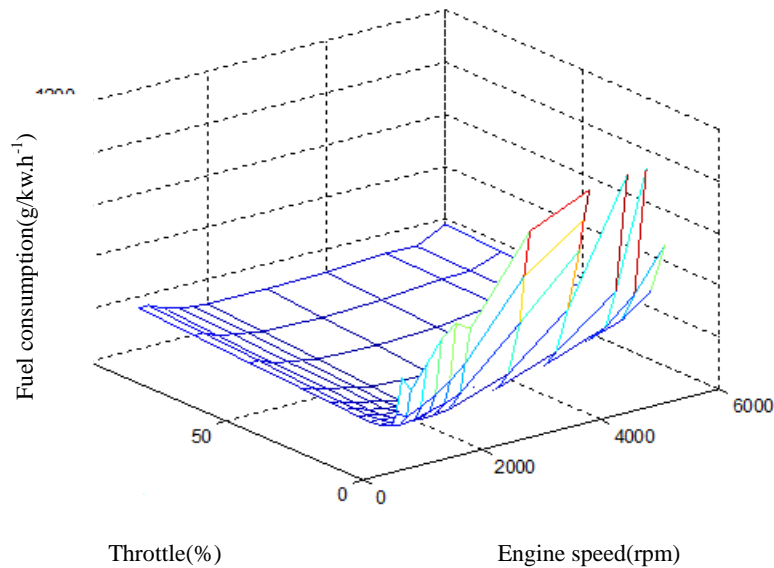

Figure 4. Engine Fuel Consumption Characteristics

3.3. The Clutch Model

Clutch model is the key to the control of shift strategy, whose working state can be divided into air travel stage, slipping stage and synchronization stage. At air travel stage, with the increase of hydraulic oil pressure, the piston moves to fight against the force of the spring, while the clutch drive plate moves to the driven plate, gradually eliminating the gap between the master and side clutch driven plates. There is no torque transmission at this stage[10].

With the further increase of the hydraulic pressure, the clutch enters the slipping stage, where the speed difference gradually decreases between the master and side transmission plates. The clutch transmission torque began to increase gradually, and the transmission torque T_{cl} can be obtained by the formula:

$$T_{cl} = \frac{z}{\pi(R_2^2 - R_1^2)} \cdot \int_0^{2\pi} \int_{R_1}^{R_2} r^2 \cdot \mu \cdot P_{cl} \cdot S dr d\theta = \frac{2}{3} \cdot \frac{R_2^3 - R_1^3}{R_2^2 - R_1^2} \cdot \mu \cdot z \cdot S \cdot P_{cl} \quad (11)$$

In the formula: μ is the coefficient of clutch friction, z is the friction surface; S is the effective function area of piston; effect; P_{cl} is the hydraulic cylinder pressure; R_1, R_2 are respectively the inner and outer radius of clutch friction plate.

In the synchronous stage, the clutch is stable, the speeds of the master and the side driven plates are equal. When the transfer torque is less than the capacity of the clutch torque, the clutch torque is equal to the current transmission torque, while when the transfer torque is bigger than the capacity of the clutch torque, the clutch torque is equal to the maximum transfer torque of the clutch.

From the above analysis, it can be known that the control of the clutch transmission torque can be realized through controlling the size of the hydraulic cylinder.

4. The Integrated Control of the Shifting

Through the fuzzy control method, the driver intention can be identified, and the shift schedule can be made and amended according to driver intention. On this basis, the DCT shift process is analyzed in detail and the corresponding control methods are made.

4.1. Identification of the Driver Intention

In the running of vehicles, intelligent control system hopes to be able to best meet the driver's different driving intention, and at the same time avoid frequent shifting and cyclic shift so as to avoid affecting the life of the clutch and synchronizer. Therefore, to identify the driver intention is very important. According to the traditional driving experience, driving intentions can be divided into parking, deceleration, cruise, acceleration and acute acceleration.

On the software platform of MATLAB, fuzzy control method is adopted to identify driver intention, fuzzy rules as shown in Table 1. In which: a fuzzy set of throttle opening a is: {positive small, positive medium, positive big}, and the corresponding fuzzy language is: {S, M, B}, the domain is: [0100]; the fuzzy set of throttle change rate da/dt is: {negative big, negative small, zero, positive small, positive big}, and the corresponding fuzzy language is: {NB, NS, Z, PS, PB}, the domain is: [-100100]; the fuzzy set of speed V : {positive small, positive medium, positive big }, the corresponding fuzzy language is: {S, M, B}, the domain is: [0100]; the fuzzy set of driver intention I t is: {parking, deceleration, cruise, acceleration, acute acceleration}, the corresponding fuzzy language is: {S, D, K, A, C}, the domain is: [-5, 5].

Table 1. Driver Intention Fuzzy Rule

| a | v | da/dt | | | | |
|-----|-----|---------|--------|---|--------|--------|
| | | N B | N S | Z | P S | P B |
| S | S | S | S | K | K | A |
| | M | S | D | K | A | A |
| | B | D | D | K | A | C |
| M | S | S | S | K | A | C |
| | M | D | D | K | A | C |
| | B | D | D | K | A | C |
| B | S | D | D | K | A | C |
| | M | D | D | K | A | C |
| | B | D | D | K | A | C |

4.2. Shift Schedule

Shift schedule is divided into the schedules of power shift and of economy shift; the former mainly pursues the acceleration performance and climbing performance of the vehicle, while the latter mainly pursues to reduce the fuel economy of the vehicle.

In order to get the best acceleration performance for the vehicle, the intersection of the two adjacent gear acceleration curves is taken as the optimal point for power shift. If there is no the intersection of the two adjacent gear acceleration curves, then the highest speed point of the low gear is taken as the shift point. Figure 5 (a) shows the acceleration characteristics of block 1 and 2. To connect each shift point at different throttle opening into a curve, you can get the power shift curve. To make appropriate amends to the shift schedule according to the driver intention, taking the acute acceleration intention of the

driver as an example to shift speed in the increase of appropriate shift schedule, to downshift in advance to enhance the dynamic performance of the vehicle so as to improve its acceleration performance can be realized. Figure 5 (b) shows shifting schedule under acute acceleration condition. Because there is no intersection between gear 4 and gear 5, gear 4 is seen as the highest speed gear.

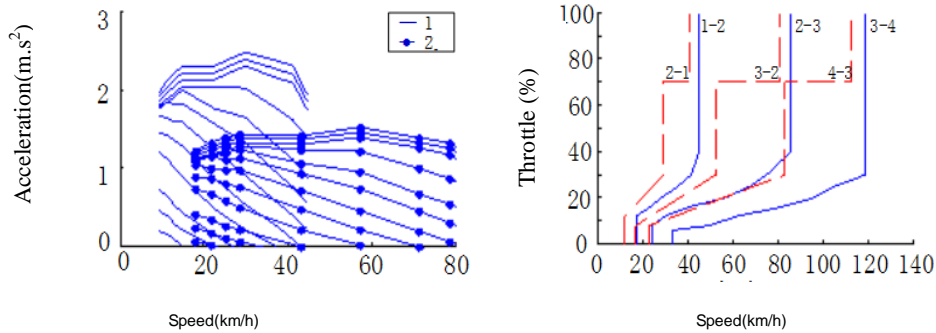

(a) the acceleration characteristics of block 1 and 2

(b) shifting schedule under acute acceleration condition

Figure 5. Dynamic Shift Characteristics

The law of economic shift takes the engine fuel consumption as its basis, the relationship between fuel consumption rate b and fuel consumption Q_e is:

$$b = \frac{60 * 1000 Q_e}{2\pi T_e n_e} \quad (12)$$

In which, T_e 、 n_e is the torque and speed of the engine. And the relationship between the engine's transmission speed and the vehicle speed is:

$$v = 7.2\pi r n_e / (60 i_n i_o) \quad (13)$$

In the formula, r 、 i_n 、 i_o are respectively the radius of the wheels, the speed ratio of each gear, and the master deceleration ratio.

Therefore, according to the characteristics of the engine fuel consumption shown in Figure 4, the fuel consumption curve of each gear can be calculated, shown in Figure 6 (a), which shows engine fuel consumption curve at block 1 and block 2. The intersection point of the oil consumption curve at adjacent gears is regarded as the shift point. If there is no intersection, then select the shift point referring to the power shift. To line the gear shift points at different throttle opening into a curve, the curve law of economic shift and what is unreasonable in the downshift control strategy according to the driver intention and delay type to make amends to the shift schedule, so as to ensure the vehicle of obtaining the best fuel economy. Figure 6 (b) shows the economy shift rule after amendment.

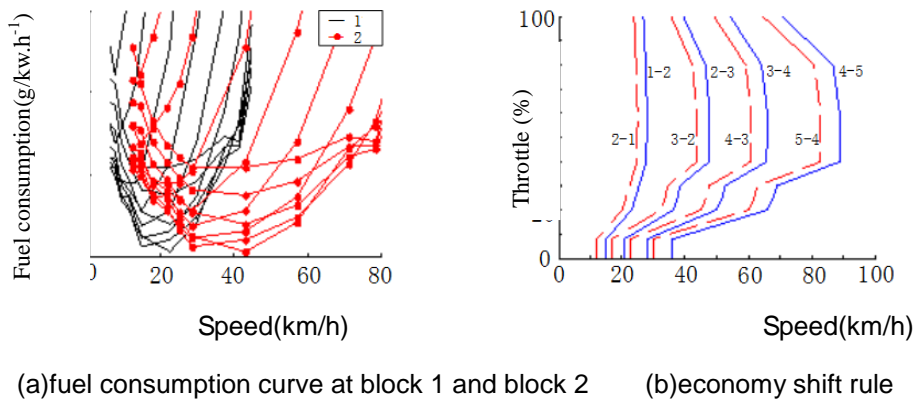

Figure 6. Economy Shift Characteristics

4.3. The Shifting Control Strategy

The shift process of dual clutch consists of two stages: the torque stage is the conversion process of torque, that is, the separation of the torque from the clutch converts to engaging to it; the inertial stage is the speed synchronization process, namely, the engine speed synchronizes with the target gear speed. When control the throttle to up shift the gear, first, entering the torque stage, and then enters the inertia stage, in the downshift process, it's the opposite.

As shown in Figure 7, taking gear I up shifting to block 2 as an example, in the torque stage, clutch C1 first separates to the sliding friction condition at a higher separation speed, at the same time, clutch C2 bonds to eliminate air travel at a faster joint speed. With the pressure on clutch 1 gradually decreased, the engaging pressure of clutch C2 gradually increases, before transmission torque size of clutch 2 meets the vehicle driving demand, C1 needs to achieve complete separation, in order to avoid power cycle. When the torque of clutch C1 is reduced to 0, it enters the inertia stage; C2 continues to engage the target torque of block 2, the master and side driven plate quickly synchronize to complete the accelerating process. In the shifting process, all the clutch pressure control is realized through fuzzy control method according to the driver intention.

At the inertial stage, clutch C1 are completely separated. To realize synchronization between the transmission speed of the engine and that of clutch C2 as soon as possible, it needs to control the engine speed to be close to the target speed. Through the reduction of throttle opening to decrease engine speed rapidly, when speed of clutch C2 synchronizes with that of the engine, solar term door engine recovers gradually until it meets the vehicle's demand. Solar term door control is realized through the fuzzy control method with a reference to driver intention.

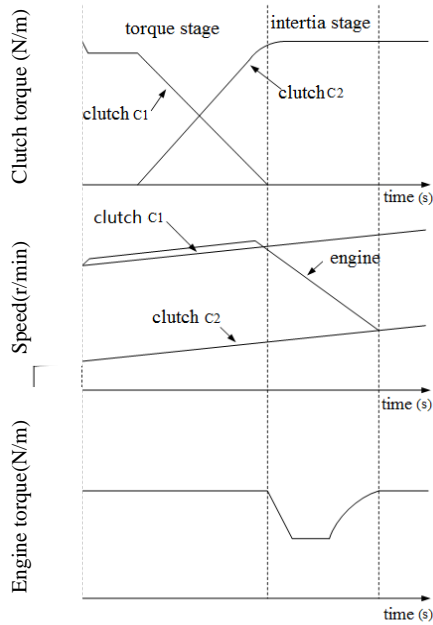

Figure 7. Rise Block Feature

4.4. The Logic of Shift Control

Through the formulation of the shift schedule the analysis of and the shifting process, comprehensive control logic of shifting are established based on DCT. Take block 1 up shift to block 2 as an example, the comprehensive control logic of shifting is mainly divided into three parts: shift identification and shifting schedule judgment, torque control stage and inertial control stage.

5. Stimulation and Analysis

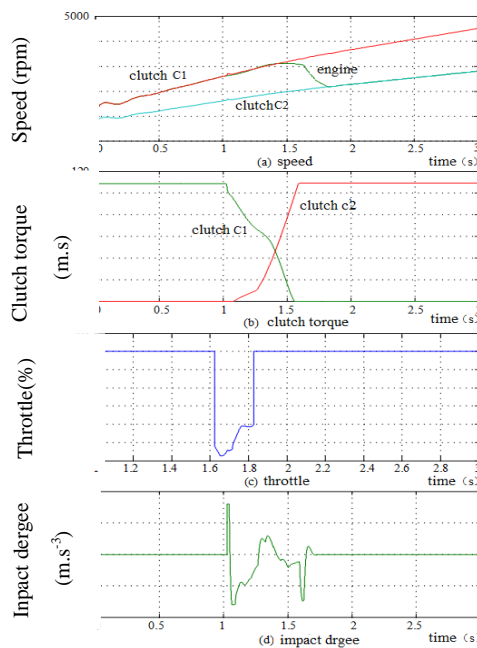

Figure 8. Simulation Results of 1 Block up 2 Block

After the integrated control analysis of the DCT shift and the formulation of control strategy, on the basis of MATLAB/Simulink simulation platform, simulation model and simulation analysis has been made on the shifting process.

Take block 1 up shift to block 2 as an example, as shown in Figure 8, it shows simulation curve of the gear shifting process at 35% throttle opening. It can be known from Figure 8 (a) that the shifting process starts from 1.04s up and ends at 1.83s with a duration of 0.79s, the shift time meets requirements; from Figure 8 (b), before clutch C2 achieves the target torque, the torque of clutch C1 has been reduced to 0 to avoid the power cycle; from Figure 8 (c), the shifting process enters the inertial stage at 1.62s, the solar term door opening of the engine quickly reduces from 35%, correspondingly, the transmission speed of the engine decrease to synchronize with clutch C2; Figure 8 (d) shows that the degree of impact in the shifting process, mainly produces in the torque stage, but it is still well controlled within 9m/s^3 , ensuring smoothness of the shifting process.

6. Conclusions

(1) Based on the structure and principle of DCT, the automobile gear shifting process is analyzed in view of dynamics and engine and clutch models are also established, which lay foundation for the subsequent formulation of control strategy of DCT shift process;

(2) Through the fuzzy control theory, respectively from the power and economy point of view, the shift schedule based on driver intention has been formulated, which establishes the foundation for the subsequent shift simulation model;

(3) The control strategy of the engine and clutch and the comprehensive shift control logic strategy are made in the ECT shifting process. Based on the MATLAB/Simulink software simulation platform, simulation model of vehicle shifting has been built, and the simulation results validates affectivity of the shift model, and it also indicates the good control effect of the formulated shift control strategy.

References

- [1] M. Goetz, M.C. Levesley and D.A. Crolla, "Integrated Powertrains Control of Gearshifts on Twin Clutch Transmissions Proceeding of Transmission and Driveling Systems Symposium[C]", 2004, SAE, (2004), pp.01-1637.
- [2] Y. Liu, D. Qin and H. Jiang, "A Systematic Model for Dynamics and Control of Dual Clutch Transmissions[J]", Journal of Mechanical Design, Transaction of ASME, vol. 131, no. 6, (2009), p. 1012.
- [3] M. Wu, J. Zhang and T. Lu, "Research On optimal control for dry dual-clutch engagement during launch[C]", Proceedings of the Institution of Mechanical Engineers, vol. 224, no. 6, (2010), pp.749-763.
- [4] K.V. Berkel, T. Hofman and A. Serrarens, "Fast and smooth clutch engagement control for dual-clutch transmissions[J]", Control Engineering Practice, vol. 22, (2014), pp. 57-68.
- [5] Y.A. Noweibin, C. Quanshi and W. Guangqiang, "The Synchroner Control Strategy for Dual Clutch Automatie Transmission Based on City Drive Cycle[J]", Journal of Mechanical Engineering, vol. 44, no. 12, (2008), pp. 243-248.
- [6] M. Jin, S. Wei and U. Guoqiang, "Research of Proving wet double clutch transmission shifting quality[J]", Modern.Manufacturing, Engineering, vol. 1, (2013), pp. 46-50.
- [7] Z. Zhiguo, W. Qi and C. Haijun, "Fuzzy Time Decision and Model-based Torque Coordinating Control of Shifting Process for Dry Dual Clutch Transmission [J]", Journal of Mechanical Engineering, vol. 49, no. 12, (2013), pp. 92-108.
- [8] Y. Liu, D. Qin and H. Jiang, "A systematic model for dynamics and control of dual clutch transmissions[J]", J. Mech. Des. Trans. ASME, vol. 131, no. 6, (2009), pp. 610-612.
- [9] E. Galvagno, M. Velardocchia and A. Vigliani, "Dynamic and kinematic model of a dual clutch transmission[J]", Mechanical Machine Theory, vol. 46, (2011), pp. 794-805.
- [10] P.D. Walker, N. Zhang and R. Tamba, "Control of Gear Shifts in Dual Clutch Transmission Powertrains [J]", Mechanical Systems Signal Process., vol. 25, (2011), pp. 1923-1936.

Author



Xiaohui Xia, is a graduate student in Nanjing University of Science & Technology, majoring in applied math. She was graduated and obtained the bachelor's degree in College of Applied Math, Nanjing University of Science & Technology.