

Fuzzy PID Control Technology for Synchronous Generator Excitation

Bo Youn and Dongwei Sun

School of Automation, Harbin University of Science and Technology, Harbin, China
youbu@hrbust.edu.cn

Abstract

Now the power system is more complicated, high efficient and rapid, the traditional PID control technology already unable to meet the needs of power system by now. In this paper, starting from the actual demand of the power system, aiming at the problem of traditional PID control parameters can not change in real time, using the method combined with theory of the fuzzy control and the traditional PID control, proposes a control system that can change the control parameters in real time—fuzzy PID excitation control system, and carries on the simulation by MATLAB/SIMULINK. Results show that the fuzzy PID control system has high performance and good real-time control, and it has better stability than traditional PID control system, it can make faster to achieve stability of the synchronous generator.

Keywords: *Generator Excitatio, Fuzzy PID Control, Simulation*

1. Introduction

The stability of the power system has been concerning and researching by power and industry academia all the time, and a control system will directly affect the quality of power system stability, so the generator excitation control system has been a key object of study [1]. The traditional excitation control are mainly constant the voltage of the generator, but with the development of electric power system and power grid, the excitation control system now to achieve high accuracy of voltage regulation, rapid response, reduce the oscillation, improve the stability of the system and a series of complex requirements [2-3].

Excitation system is a closed loop system composed by excitation control, synchronous generator and detecting link. The control method of the excitation control is key to determining an excitation system performance; an excitation system directly affects the stability and reliability of generator operation. With the classical control theory has been developed into a mature stage in 1950s, and the generator is also using DC exciter excitation mode, so the PID and PID excitation control got a large number of applications by generator terminal voltage deviation as feedback [4]. With the development of control theory and hardware technology, today's traditional PID control technology has been quite mature, it has simple algorithm, clear structure, convenient adjustment, rich experience in application and other aspects of advantage[5-6]. But at the same time, the shortcomings of traditional PID are exposed, it is only used for single variable linear time-invariant systems, can not balancing the performance of multiple variables at the same time, is not suitable for multi-variable, time-varying, nonlinear an uncertain complex system; the adjustment of the deviation value must be continuous, unable to determine the change of controlled object; the control parameters fixed, can't be adjustment in the real-time, can't have rapid response for the change of controlled object and change operation parameters according to the changing situation [7-8].

Now the power system developing as multi unit, large capacity and more complex, the power system has developed into a large multidimensional dynamic system which has strong nonlinear and time-varying, so the traditional PID control will not be able to meet the more complicated power system in the future. In this paper, combines fuzzy control and PID control, realized the parameters can be real-time change, in order to solve the problems of slow response and poor stability in traditional PID which caused by can't change the parameters in real-time. Theory analysis shows that, due to the fuzzy PID control system can judge the real-time change of the controlled system, through the sampling of deviation analysis in real-time to changing the control parameters which can better control of the controlled object, and achieve a more rapid response, more stable output than traditional PID [6]. Through the simulation results show that the fuzzy PID control in robustness, real-time performance, stability and other aspects are better than traditional PID control.

2. Synchronous Generator Excitation Control System

Synchronous generator excitation control system is a closed loop control circuit composed by excitation regulation unit, power unit, synchronous generator and voltage measuring unit.

In this paper, the experiment model is replaced by transfer function, which the synchronous generator is rated speed and maximum voltage is rated voltage, so it can be ignored the saturation phenomenon in the process of experiment, therefore, the transfer of synchronous generator can be represent by a first-order lag link.

$$G_G(s) = K_G / (1 + T_G s) \quad (1)$$

In the formula: T_G is the time constant, mainly indicates the time constant of the excitation winding, K_G is the amplification factor of synchronous generator, general expression by ratio of the stator voltage and no-load rotor voltage.

Voltage measurement unit is composed of transformer and rectifier filter circuit, is used to convert the terminal voltage into DC voltage, convenient detection. The transfer function can be expressed as a first-order lag link:

$$G_M(s) = K_M / (1 + T_M s) \quad (2)$$

In the formula: the time constant T_M is generally tens of milliseconds, K_M is the ratio of measuring unit output and the corresponding input voltage.

3. Design of Fuzzy PID Controller

3.1. Fuzzy Control Principle

Fuzzy control theory is put forward by American professor Zadeh L A in 1973[7, 9], the basic idea of fuzzy control is to use linguistic variables instead of a precise mathematical variables, using the fuzzy relationship instead of precise mathematical relationship, using a simple fuzzy algorithm instead of large and complicated calculation, fuzzy control component three part by fuzzification, fuzzy reasoning and deblurring.

3.2. Fuzzy PID Controller Principle

In order to meet the different time input requirements for controller parameters self-tuning, fuzzy controller with error e and error change rate ec as input, output parameters of PID after through fuzzification, fuzzy inference and deblurring

operation, so that can meet different time of e and ec on PID parameters self-tuning requirements. Fuzzy PID control principle is shown in Figure 1.

By the figure, can see that the whole system of control part composed by traditional PID controller and the fuzzy control part. Common control method of PID controller is based on the error of the controlled object to return values to the output control signal, the control of the PID parameters are fixed, can not change in real time, when power grid is under large disturbance or sudden and sharp reduction of the load, the fixed parameters of type PID cannot regulation quickly on the oscillation of steady. After adding fuzzy controller of the control mode makes the control parameters of controller for real-time variable, it solves the above problems, fuzzy controllers will be sampled on the error and error change rate, according to the feedback value can control the three parameters of P, I, D the real time, and then the input control parameters change to the PID controller, let the control system can control the real time change of the controlled object.

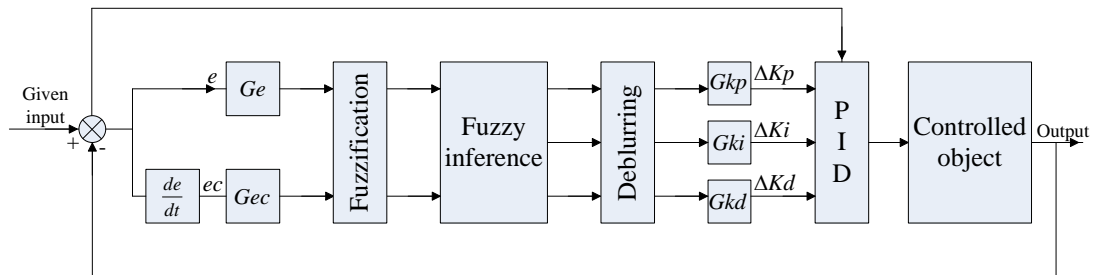

Figure 1. Fuzzy PID Control System Structure

Ge and Gec in figure respectively for quantitative factors e and ec , Gk_p, Gk_I, Gk_D respectively for the scale factor of K_u which is the fuzzy quantity of the output. Ge, Gec is the role let the input variables from the basic domain conversion to the fuzzy domain, Gk_p, Gk_I, Gk_D will transform control quantity to the basic domain which the control object can accept.

The basic domain of e and ec are respectively $[-e_{\max}, e_{\max}]$ and $[-ec_{\max}, ec_{\max}]$, The basic domain of the output is $[-u_{\max}, u_{\max}]$, then

$$Ge = \frac{n}{e_{\max}}, Gec = \frac{m}{ec_{\max}}, Gk_p = \frac{u_{\max}}{l_1}, Gk_I = \frac{u_{\max}}{l_2}, Gk_D = \frac{u_{\max}}{l_3} \quad (3)$$

In the type, n and m is the maximum value of output fuzzy domain which respectively e and ec , l_1, l_2, l_3 is the maximum value of the fuzzy domain for K_u .

3.3. Determine of Membership Degree

In the traditional excitation control, the formula for traditional PID controller is [11-12]:

$$u(t) = K_p e(t) + K_I \int_0^t e(t) dt + K_D \frac{de(t)}{dt} \quad (4)$$

After join the fuzzy controller, parameters P, I, D into real time variable, so the whole control formula becomes:

$$u(t) = (K_p + \Delta K_p)e(t) + (K_I + \Delta K_I) \int_0^t e(t)dt + (K_D + \Delta K_D) \frac{de(t)}{dt} \quad (5)$$

In the type, ΔK_p , ΔK_I , ΔK_D is $K_u \times Gk_u$. Here we need to determine the membership of each state, according to the different personal experiment, the basic domain of e and ec in this paper is $[-6, -4, -2, 0, +2, +4, +6]$, the basic domain of output is $[-3, -2, -1, 0, +1, +2, +3]$, and the input and output linguistic variables are [NB(negative big), NM(negative middle), NS(negative small), Z(zero), PS(positive small), PM(positive middle), PB(positive big)] according to the establishment of language variable, can get the membership functions are as shown in figure 2 and figure 3 [13].

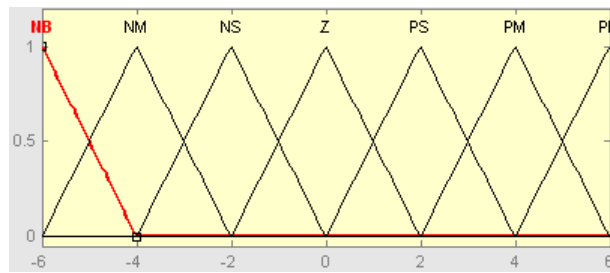

Figure 2. Membership Function of Error and Error Change Rate

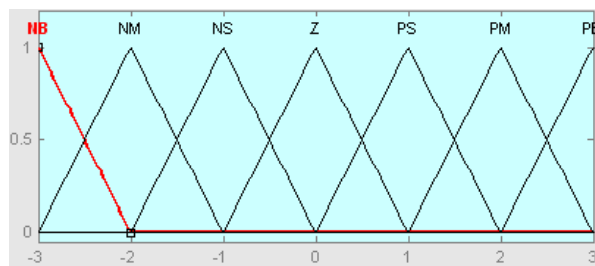

Figure 3. Membership Function of Output Control Quantity

3.4. The Establishment of Fuzzy Rules

Fuzzy rules is the core of a fuzzy controller, its role is to adjust PID parameters in real time, so the establishment of fuzzy rules is directly related to the control effect of the whole control system, the fuzzy rule is work out by designers and engineers of design experience and long-term work summary. According to the analysis of the traditional PID control characteristic curve, the PID parameter tuning rules can be set as follows [9-10]:

(1) When the controlled object is started, and the input error of e is large, should eliminate the error of the system to achieve stability as soon as possible, so have to improve the response speed of system, thus can choose the larger K_p ; also need to avoid the differential saturated caused by early big change of error rate, so take K_D smaller; at the same time, in order to avoid a large overshoot, so take $K_I = 0$.

(2) When normal operation, error and error change rate in medium size, should use a smaller control efforts, therefore, should be appropriate to reduce the K_p , K_I and K_D take the appropriate value.

(3) When the system basically stable, the feedback error is small, to make the system has good stability, can be appropriate to increase the K_p and K_I ; at the same

time in order to avoid the oscillation phenomenon near the set value of system, so the value of K_D is very important, in general, the low error rate of change can take larger K_D , the large error rate of change can take smaller K_D .

According to the rules above, it can be summed up fuzzy control table as shown in Table 1.

Table 1. Fuzzy Control Rules

$\begin{matrix} ec \\ e \end{matrix}$	NB	NM	NS	Z	PS	PM	PB
NB	PB/N B/PS	PB/N B/NS	PM/ NM/NB	PM/ NM/NB	PS/N S/NB	PS/Z/ NM	Z/Z/P S
NM	PB/N B/PS	PB/N B/NS	PM/ NM/NB	PS/N S/NM	PS/N S/NM	Z/Z/ NS	NS/Z/ Z
NS	PM/ NM/Z	PM/ NM/NS	PM/ NS/NM	PS/N S/NM	Z/Z/ NS	NS/P S/NS	NS/P S/Z
Z	PM/ NM/Z	PM/ NM/NS	PS/N S/NS	Z/Z/ NS	NS/P S/NS	NM/ PM/NS	NM/P M/Z
PS	PS/N M/Z	PS/N S/Z	Z/Z/Z	NS/P S/Z	NS/P S/Z	NM/ PM/Z	NM/P B/Z
PM	PS/Z/ PB	Z/Z/P S	NS/P S/PS	NM/ PS/PS	NM/ PM/PS	NM/ P/PS	NB/P B/PB
PB	Z/Z/P B	Z/Z/P M	NM/P S/PM	NM/P M/PM	NM/P M/PS	NB/P B/PS	NB/P B/PB

It can be seen when the system error e and error change rate ec exists in different fuzzy interval, ΔK_p , ΔK_i , ΔK_d three variables take different fuzzy interval.

4. Simulation Research

4.1. Simulation Model

This paper uses the MATLAB/SIMULINK software, the fuzzy PID control module as shown in Figure 4 which mainly discussed.

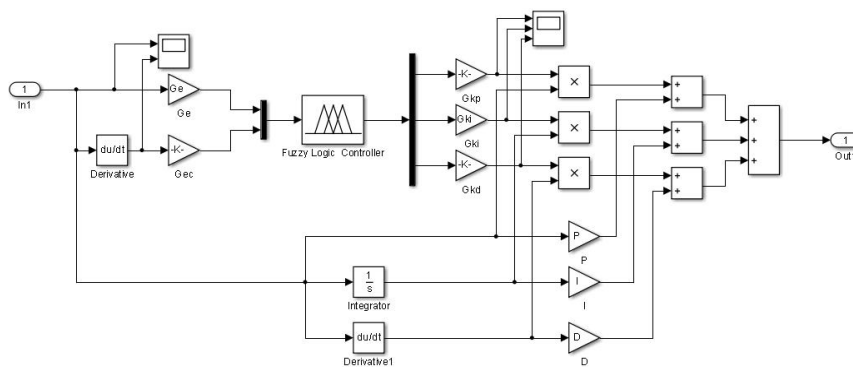

Figure 4. Fuzzy PID Control Module

It can see that the modules are combined together by fuzzy controller and PID controller, it is same as the basic framework of fuzzy controller which proposed in the second chapter. Figure of logic control module uses the classic Mamdani fuzzy reasoning model, the control rules as^{[7][9]}: if $x_1 = A_1^i, x_2 = A_2^i, x_3 = A_3^i, \dots, x_n = A_n^i$, then $y = B_j$. The control statements such as if (e is NB) and (ec is NB) then (Kp is PB) and (Ki is NB) and (Kd is PS). A package above fuzzy PID controller, to join the whole simulation model is shown in Figure 5.

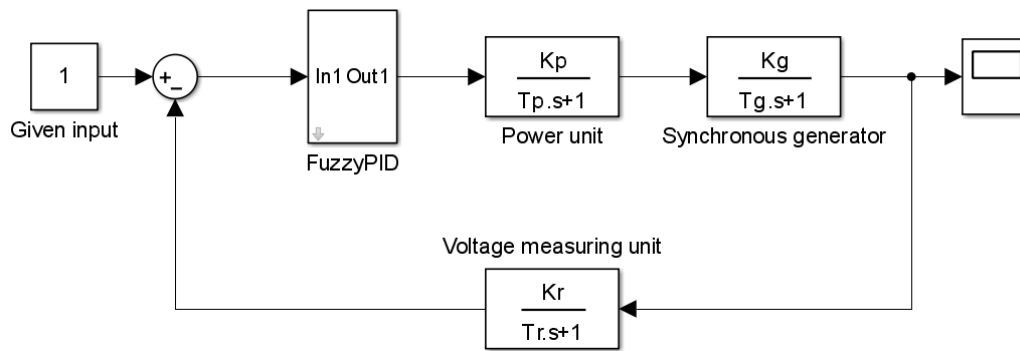

Figure 5. Simulation Model

4.2. Simulation Results and Analysis

According to the multiple set of parameters, the simulation experiments and analysis, finally the simulation data set as follows: $Kp = 60$; $Ki = 10$; $Kd = 0.3$; $Ge = 6$; $Gec = 6$; $Gkp = 26.67$; $Gki = 13.33$; $Gkd = 0.533$. This paper presents performance comparison of traditional PID and fuzzy PID which under the rev machine and sudden add or subtract the load.

- (1) Simulation the process of excitation system start from zero, rated input values are given for 1, the waveform comparison of fuzzy PID controller and traditional PID controller is shown in Figure 6.

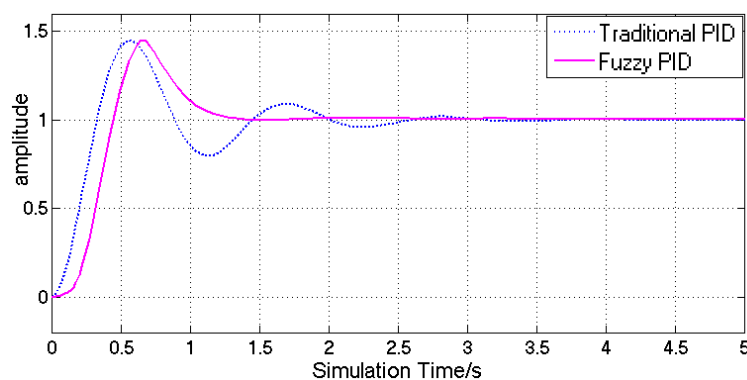

Figure 6. Start Control Comparison

It can see that the fuzzy PID controller after a concussion can quickly reach the steady state performance, far quicker than traditional PID.

- (2) After the startup waveform is stable, plus twenty percent load when six second, the waveform comparison is shown in Figure 7. Subtract twenty percent load at ten second, the waveform comparison is shown in Figure 8.

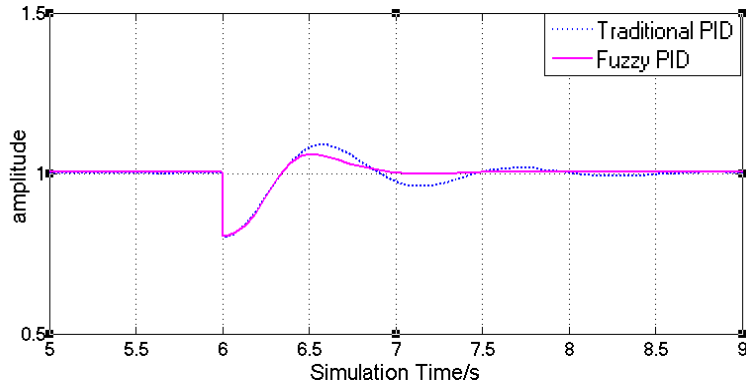

Figure 7. Sudden Load Waveform Comparison

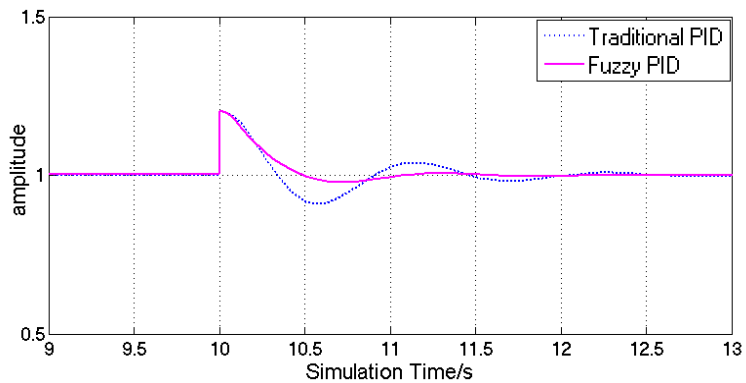

Figure 8. Remove the Load Waveform Comparison

As can be seen, the waveform mutation after sudden load or remove the load, fuzzy PID control system can make the output quickly reaches a stable state, and the oscillation amplitude is small, while the output of the traditional PID reaches stable state after many oscillations.

5. Conclusion

Through the simulation and analysis of this article, from the theoretical analysis, the fuzzy PID can control parameters in real time based on the real-time situation of feedback, make the control system can controlled in different strengths based on the different status of controlled object, to achieve the optimal control under different condition, this control method is definitely better than the traditional PID control. From the analysis on the simulation experiment, although in the start-up and load suddenly increased or decreased, the traditional PID can reach the national standard requirements, but can be seen from the simulation graph, fuzzy PID control effect is superior to traditional PID controller, especially in terms of stability, small vibration amplitude, and small vibration frequency. But at the moment, in the practical application of fuzzy PID controller has not been very good practice and development, but with the development of electric power system, power grid is more and more complex, a large number of micro power grid come out, traditional PID must not to meet the requirements, combined with the PID controller of intelligent control will become an important direction of development.

References

- [1] C. Qiming, C. Yinman, X. Yang and H. Xiaoqing, "Development and prospects of excitation control methods for synchronous generator, Electric Power Automation Equipment", 5, 32 (2012)
- [2] H. Yingduo, X. Xiaorong and C. Wenjin, "Status quo and future trend in research on synchronous generator excitation control", Tsinghua Univ: Sci&Tech. 4/5, 41 (2011)
- [3] T. Yonghua, "New type of PID control and its application", China Machine Press, (2002)
- [4] L. Jicheng, "Design and application of modern synchronous generator excitation system", China Electric Power Press, (2009)
- [5] H. Xiaofeng, "The application of PID in generator excitation control system", Transaction of China Electrotechnical society. 9 (2007)
- [6] L. Ang, "PID control simulation of synchronous generator excitation system", Electronic Design Engineering. 2, 19 (2011)
- [7] J. Deli and Y. Bo, "Study on novel plasma arc cutting technology based on PIDNN-FUZZY controller", International Journal of Innovative Computing, Information and Control. 7 (2011)
- [8] H. Yamin, "Research of excitation control for synchronous machines with brushless excitation system", South China University of Technology, (2013)
- [9] W. Lixin, "Fuzzy systems and fuzzy control course", Tsinghua University Press, (2003)
- [10] Wang Shuyan, Shi Yu and Feng Zhongxu, A method for controlling a loading system based on a fuzzy PID controller, Mechanical Science and Technology for Aerospace Engineering. 1, 30 (2011)
- [11] W. Jie, L. Yongqiang and C. Wei, "The application of modern control techniques in power system control", Proceedings of the CSEE. 6, 18 (1998)
- [12] W. Bin, "Research of the synchronous generator excitation control system based on simulation", Nanchang University, (2007)
- [13] J. Deli, W. Sunzhen, W. Qiong and X. Peng, "A switching-inverter power controller based on fuzzy adaptive PID", The 6th International Forum on Strategic Technology.