

Effect of TCVR Controlled Voltage on Short-Circuit Calculations in Case of Ground Fault in the Algerian Network

Mohamed Zellagui¹, Heba Ahmed Hassan², and Abdelaziz Chaghi¹

¹*Department of Electrical Engineering, Faculty of Technology,
University of Banta, Algeria*

²*Department of Electrical and Computer Engineering, College of Engineering,
Dhofar University, Sultanate of Oman & Electrical Power and Machines
Department, Faculty of Engineering, Cairo University, Giza, Egypt
m.zellagui@univ-batna.dz, hebahassan@ieee.org, az_chaghi@univ-batna.dz*

Abstract

Flexible AC Transmission Systems (FACTS) technology has been developed to control voltage and reactive power in power systems by incorporating high speed power electronic devices. The FACTS device presented in this research work is Thyristor Controlled Voltage Regulator (TCVR) which is a novel FACTS device that aims to control system voltage and hence improves voltage regulation. This paper studies the effect of voltages injected by TCVR, whether positive or negative, on short-circuit calculations. The type of fault considered is a ground fault that occurs at the end of a high voltage line compensated at its mid point by TCVR while maintaining a fixed fault resistance. A case study is selected for a high voltage power line in the Algerian transmission network. In this research work, the illustrated simulation results show perfect agreement with the presented theoretical analysis which is based on the method of symmetrical components.

Keywords: *Power Systems, Transmission Line, Voltage Control, Flexible AC Transmission Systems (FACTS), Thyristor Controlled Voltage Regulator (TCVR), Symmetrical Components, Ground Fault*

1. Introduction

Fault analysis of a power system is essentially required to provide information for the selection of switch-gears, setting of relays, and stability of system operation in general. Fault current calculations are normally made at the design stage of the system to determine the short-circuit ratings of new switchgear and infrastructure equipment. System reinforcements may be triggered by network expansion and/or the connection of a new generating plant to the power system. Routine calculations are also made to check the continued adequacy of existing equipment as system operating configurations are modified [1].

Fault current calculation approach is formulations which are normally used to analyze faults in power systems that estimate the during-fault system state. These approaches and algorithms can be used to provide the settings and coordination of protection relays. In addition, calculations of minimum fault currents are made and these are used in the calculation of protection relay settings to ensure accurate and coordinated relay operations.

Fault currents in transmission systems must be quickly cleared to avoid loss of synchronism of generation plant and major power system blackouts. Maximum fault current calculations are carried out for the design of substation earth electrode systems.

Many researchers have worked in the area of fault analysis in power systems which addresses symmetrical and unsymmetrical single or multiple faults. Single faults occur at

a single location in the network while multiple faults occur at multiple locations simultaneously. Simple faults involve only a single type of faults such as line to ground, line to line and double line to ground faults. Complex faults involve a combination of the simple faults that may occur simultaneously in the network. Fault calculations due to multiple faults at different locations in power systems were considered in [2], a canonical model for the study of faults in power systems was addressed in [3], and a method to calculate the effects of mutual coupling in multi faults and incorporating the zero sequence mutual coupling effects among multi parallel routes was discussed in [4]. In [5], the calculation of simultaneous faults in power systems was investigated. A systematic short-circuit analysis method for unbalanced distribution systems based on exact three phase models and two relationship matrices of distribution systems was presented in [6], while [7] described a generic approach to the analysis of faulted power systems in three phase coordinates. The influence of mutual coupling between parallel transmission lines on single line-to ground and double line-to-ground faults was discussed in [8] and a detailed analysis of the apparent impedance as seen from the relaying point due to faults on parallel transmission lines was presented in [9]. A new calculation method of the ground fault current distribution along non-uniform multi-section line and cable was proposed in [10], a piecewise solution procedure for fault studies using large change sensitivity concept was suggested in [11], and a systematic approach for applying the three terminal Thévenin's equivalent circuit to three terminal elements was proposed in [12].

In power systems, it is well known that high loading and voltage drops can adversely affect on system operation under steady-state conditions. This can be resolved by providing reactive power to improve load power factor and compensate for reactive power losses in lines and transformers. Before the development of FACTS devices, mechanically switched shunt capacitors and reactors were traditionally used for voltage control which resulted in some voltage control problems.

FACTS technology came to present a family of new high-speed electronic devices which can significantly increase the power system performance by delivering or absorbing real and/or reactive power, [13]. One of the novel FACTS devices is Thyristor Controlled Voltage Regulator (TCVR) which is employed in this work.

This paper studies the impact of the controlled TCVR voltage on ground fault parameters in the presence of phase (A) to earth fault at the end of a high voltage transmission line. The considered case study is for a 400 kV transmission line in the Algerian power network compensated by TCVR at the mid of the line. This line connects two substations, namely Salah Bey (Sétif) and Bir Ghablou (Bouira) in Algeria. The effect of the positive/negative applied TCVR voltage, given by V_{TCVR} , is studied for ground fault parameters which are symmetrical current components (I_1 , I_2 and I_0), transmission line currents (I_A , I_B and I_C), voltage symmetrical components (V_1 , V_2 and V_0), and transmission line voltages (V_A , V_B and V_C). In this study, a fixed value for fault resistance and location are maintained throughout analysis and simulations.

2. Thyristor Controlled Voltage Regulator (TCVR)

In dynamic stability studies of power systems, the rapid speed of FACTS devices offers several benefits to system operation and control. In particular, they are capable of increasing the synchronizing torque, damping oscillations at various frequencies below the rated frequency, supporting dynamic voltage or controlling power flows. Moreover, FACTS devices may have benefits in case of fault, by limiting the fault current [14]. Another advantage of FACTS devices is considered in the ability of this technology to extend the current transmission line limits in a

step-by-step manner with incremental investment when required. Furthermore, it offers the possibility to move an installation when it becomes not useful anymore. Different types of devices have been developed and there are various ways to classify them in terms of the technology of the used semiconductor, the possible benefits of the controllers, and the type of compensation. Figure 1 shows the active power flow equation between two buses 1 and 2 and the variables that can be modified by each FACTS device [15].

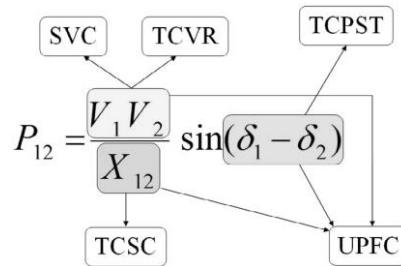

Figure 1. Impacts of FACTS Devices on Active Power Equation

V_1 and V_2 are the voltage magnitudes at bus-bars 1 and 2, X_{12} is the reactance of the transmission line and $(\delta_1 - \delta_2 = \delta)$ is the difference angle between V_1 and V_2 phasors. TCVR operates by inserting an in-phase voltage to the main bus voltage to change its magnitude. To model TCVR, an ideal tap changer transformer can be used without series impedance as shown in Figure 2. The value of the turns ratio is given by the ratio of the additional transformation relative to the nominal transformation and its values range from 0.9 to 1.1, where 1.0 corresponds to no additional transformation [14].

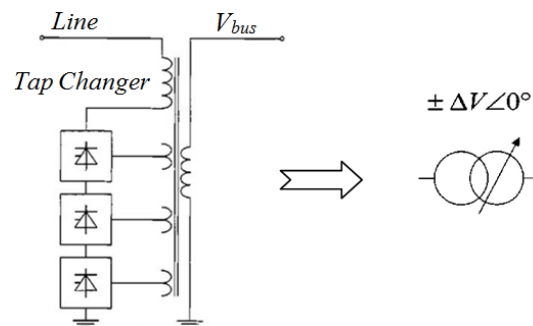

Figure 2. Model of TCVR

Therefore, TCVR can be modeled as an ideal tap changer transformer without series impedance [14, 16]. The TCVR coefficient, denoted by K_{TCVR} , has the following ranges:

$$V_{TCVR} = K_{TCVR} \cdot V_{bus} \quad (1)$$

$$-0.15 \leq K_{TCVR} \leq +0.15 \quad (2)$$

$$-0.15 \times V_{bus} \leq V_{TCVR} \leq +0.15 \times V_{bus} \quad (3)$$

3. Ground Fault Parameters in the Presence of TCVR

In 1918, C.L. Fortescue presented the symmetrical components method which has been popular ever since [16, 17] which is used in this paper. This method has always been employed in the analysis of unbalanced three-phase systems, unsymmetrical fault currents, and rotating electro-dynamics machinery.

Figure 3 shows the equivalent circuit of a transmission line compensated by TCVR in case of a phase to ground fault (F) at phase A. A fixed fault resistance R_F is used and the fault location occurs at bus-bar B .

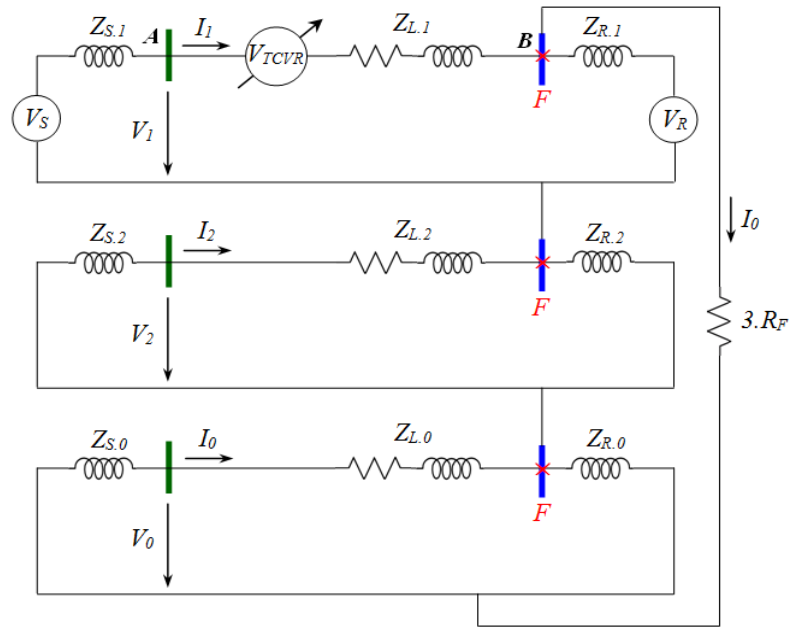

Figure 3. Ground Fault Equivalent Circuit with TCVR

The basic equations for this type of fault [17-19] take the following form:

$$I_B = I_C = 0 \quad (4)$$

$$V_A = V_1 + V_2 + V_0 = R_F \times I_A \quad (5)$$

The symmetrical components of the currents are [1, 20]:

$$\begin{bmatrix} I_0 \\ I_1 \\ I_2 \end{bmatrix} = \frac{1}{3} \begin{bmatrix} 1 & 1 & 1 \\ 1 & a & a^2 \\ 1 & a^2 & a \end{bmatrix} \begin{bmatrix} I_A \\ I_B \\ I_C \end{bmatrix} \quad (6)$$

From equation (4) and matrix (6), the symmetrical components of the currents take the following form:

$$I_1 = I_2 = I_0 = \frac{I_A}{3} \quad (7)$$

The symmetrical components of the voltages are [1, 20]:

$$\begin{bmatrix} V_0 \\ V_1 \\ V_2 \end{bmatrix} = \frac{1}{3} \begin{bmatrix} 1 & 1 & 1 \\ 1 & a & a^2 \\ 1 & a^2 & a \end{bmatrix} \begin{bmatrix} V_A \\ V_B \\ V_C \end{bmatrix} \quad (8)$$

From equation (5) and the matrix in equation (8), the direct voltage component becomes:

$$V_1 = -(V_0 + V_2) + (R_F \times I_A) \quad (9)$$

Hence,

$$V_s \pm V_{TCVR} - M_1 = -\frac{1}{3}(-M_0) - \frac{1}{3}(-M_2) + (R_F \times I_A) \quad (10)$$

where,

$$\begin{aligned} M_1 &= Z_{L.1} \times I_1 \\ M_0 &= Z_{L.0} \times I_0 \end{aligned} \quad (11)$$

$$M_2 = Z_{L.2} \times I_2$$

$$V_s \pm V_{TCVR} = \frac{I_A}{3} (Z_{L.1} + Z_{L.2} + Z_{L.0}) + (R_F \times I_A) \quad (12)$$

From equations (12), the current of phase (A) in the presence of TCVR is given by:

$$I_A = \frac{3 \times (V_s \pm V_{TCVR})}{Z_{L.1} + Z_{L.2} + Z_{L.0} + (3 \times R_F)} \quad (13)$$

From equations (7) and (13), the symmetrical components of the currents in the presence of TCVR are given by:

$$I_1 = I_2 = I_0 = \frac{V_s \pm V_{TCVR}}{Z_{L.1} + Z_{L.2} + Z_{L.0} + (3 \times R_F)} \quad (14)$$

The direct component of the phase voltages of the line is defined by:

$$V_1 = V_s \pm V_{TCVR} - M_1 \quad (15)$$

$$V_1 = \frac{(V_s \pm V_{TCVR}) \times [Z_{L.2} + Z_{L.0} - (2 \times Z_{L.1}) + (3 \times R_F)]}{Z_{L.1} + Z_{L.2} + Z_{L.0} + (3 \times R_F)} \quad (16)$$

The inverse component of the voltages is defined by:

$$V_2 = -M_2 \quad (17)$$

$$V_2 = -\frac{(V_s \pm V_{TCVR}) \times Z_{L.2}}{Z_{L.1} + Z_{L.2} + Z_{L.0} + (3 \times R_F)} \quad (18)$$

The zero component of the voltages is given by:

$$V_0 = -M_0 - (R_F \times I_0) \quad (19)$$

$$V_0 = - \frac{(V_S \pm V_{TCVR}) \times (Z_{L.0} + R_F)}{Z_{L.1} + Z_{L.2} + Z_{L.0} + (3 \times R_F)} \quad (20)$$

The coefficients are defined as:

$$A_a = a^2 - a \quad (21)$$

$$A_b = a^2 - 1 \quad (22)$$

$$A_c = 3 \times a^2 - 1 \quad (23)$$

$$A_d = a - a^2 \quad (24)$$

$$A_e = a - 1 \quad (25)$$

$$A_f = 3 \times a - 1 \quad (26)$$

From equations (16), (18), (20) and matrix (8), the three phase voltages of the line in the presence of TCVR take the following form:

$$V_A = \frac{3 \times R_F \times (V_S \pm V_{TCVR})}{Z_{L.1} + Z_{L.2} + Z_{L.0} + (3 \times R_F)} \quad (27)$$

$$V_B = \frac{(V_S \pm V_{TCVR}) \cdot [A_a \times Z_{L.2} + A_b \times Z_{L.0} + A_c \times R_F]}{Z_{L.1} + Z_{L.2} + Z_{L.0} + (3 \times R_F)} \quad (28)$$

$$V_C = \frac{(V_S \pm V_{TCVR}) \times [A_d \times Z_{L.2} + A_e \times Z_{L.0} + A_f \times R_F]}{Z_{L.1} + Z_{L.2} + Z_{L.0} + (3 \times R_F)} \quad (29)$$

Therefore, in case of maintaining a fixed fault resistance and a specified fault location, it is concluded that fault calculations are only depending on TCVR controlled voltage denoted by V_{TCVR} and its operation mode.

4. Case Study and Simulation Results

The case study considered in this research work is for a 400 kV transmission line in the northern part of the Algerian power network, as shown in Figure 4 [21, 22]. TCVR is installed at the mid of this transmission line that connects bus-bar *A* at Salah Bey (Sétif) substation with bus-bar *B* at Bir Ghablou (Bouira) substation. The TCVR data and transmission line parameters are given in [21] where the authors investigated the effect of varying the fault resistance on short-circuit calculations. In this paper, authors investigate the impact of positive and negative TCVR controlled voltages on short-circuit calculations for a single phase to ground fault that happens at bus-bar *B* for the same case study. The fault occurs at phase *A* of the specified line, while in this case a fixed fault resistance is maintained at 20 Ω .

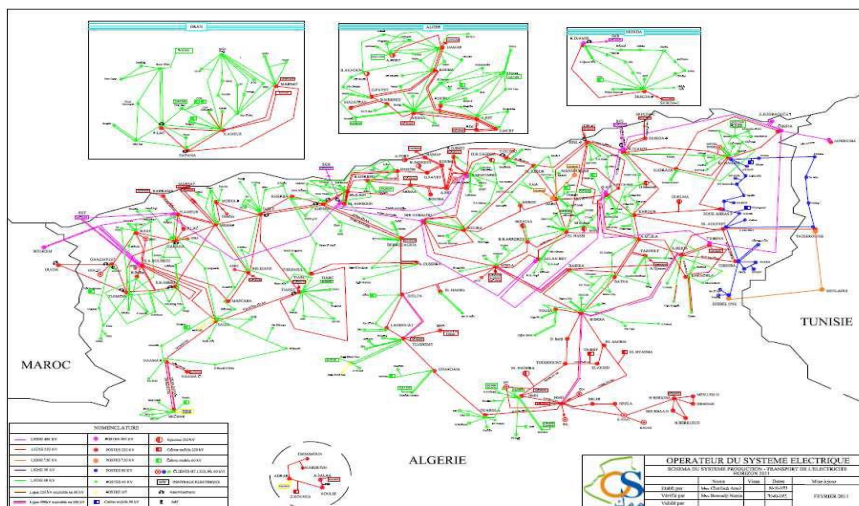

Figure 4. Algerian Power Transmission Network

Figure 5 shows the effect of positive and negative TCVR controlled voltages on active power (P_L) of the line during the variation of power angle (δ). From that figure, the obtained responses, when using TCVR, can also be compared with the power flow across the uncompensated line.

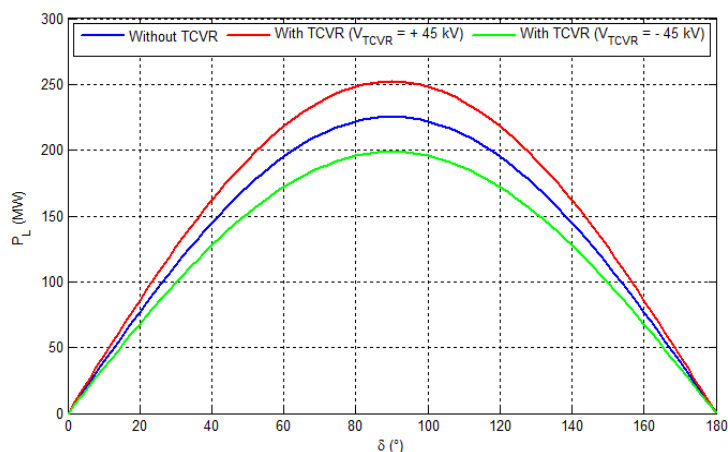

Figure 5. Impact of V_{TCVR} on P_L

As illustrated in Figure 5, the presence of TCVR at the mid of the transmission line leads to an increase of the active power P_L in case of positive injected voltage and a corresponding reduction in case of a negative voltage injected by TCVR when compared with active power flow in case of not using TCVR.

Figures 6.a, b, c represent the variation of the current symmetrical components I_1 , I_2 and I_0 , respectively and Figures 7.a, b, c represent the variation of the phase currents of the line I_A , I_B and I_C , respectively as a function of V_{TCVR} when using TCVR and without. Figures 8.a, b, c represent the variation of the voltage symmetrical components V_1 , V_2 and V_0 , respectively and Figures 9.a, b, c represent the variation of the phase voltages of the line V_A , V_B and V_C , respectively as a function of V_{TCVR} in case of using TCVR and without. In case of not using TCVR, each of the above mentioned short-circuit parameters under investigation maintains a fixed value which is certainly irrespective of the change of TCVR voltage as there is no compensation in such cases.

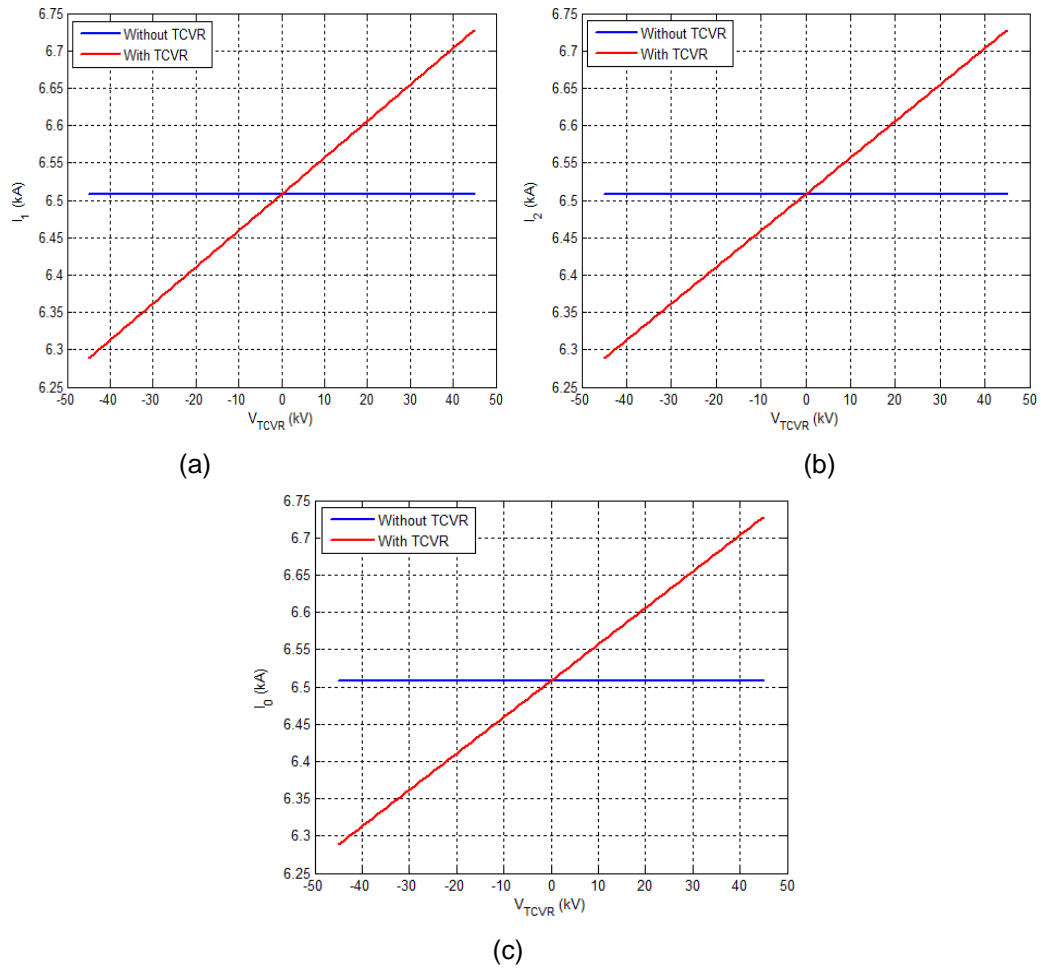
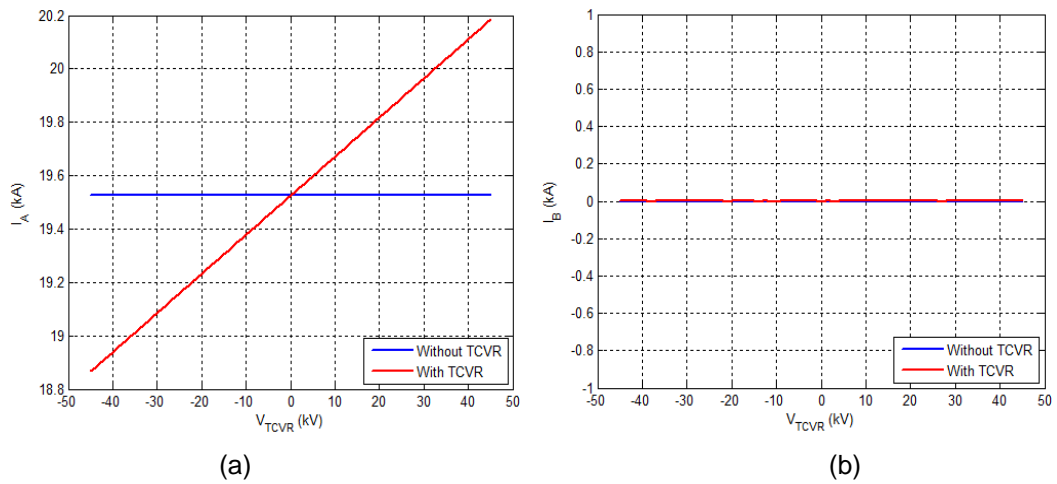
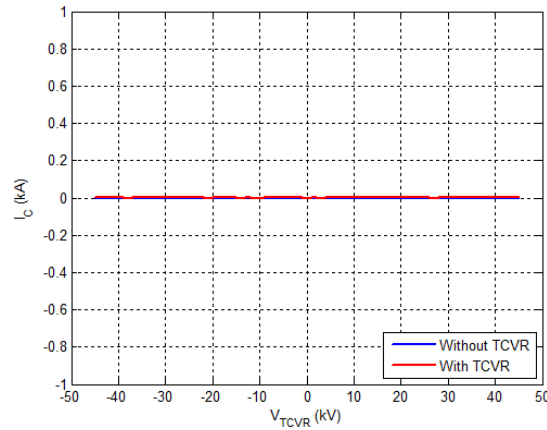

Figure 6. Impact of V_{TCVR} on Current Symmetrical Components of the Line:
 a). $I_1 = f(V_{TCVR})$, b). $I_2 = f(V_{TCVR})$, c). $I_0 = f(V_{TCVR})$





(c)

Figure 7. Impact of V_{TCVR} on Transmission Line Currents:
 a). $I_A = f(V_{TCVR})$, b). $I_B = f(V_{TCVR})$, c). $I_C = f(V_{TCVR})$

Figures 6.a, b, c, shows that the three symmetrical currents are equal, in case of using TCVR and without using it, which matches equation (7). In case of using TCVR, it is clear that increasing the value of V_{TCVR} leads to increasing the value of the three current symmetrical components. For example, in case of negative injected voltage, the value of each of the three current symmetrical components is higher in the absence of TCVR than its value when using TCVR. In case of positive injected voltage, the value of each of the three current symmetrical components is higher when using TCVR than its value without using it.

In Figures 7.a, b, c, it is noticeable that the line currents of phases B and C are always zero which is confirmed by equation (4). However, increasing the value of V_{TCVR} shows an increase in the line current of the faulty phase (A) when using TCVR. In case of negative injected V_{TCVR} voltage, the value of the line current of the faulty phase (A) is lower when using TCVR than its value without using it. In case of positive injected voltage, the value of I_A is higher in the presence of TCVR than its value without TCVR.

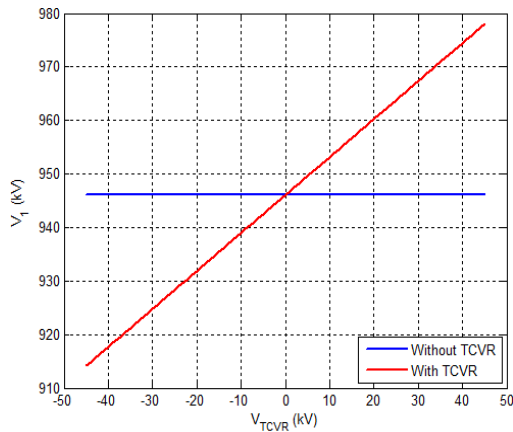

(a)

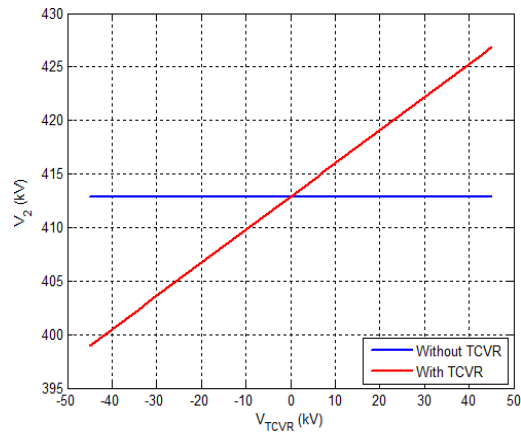

(b)

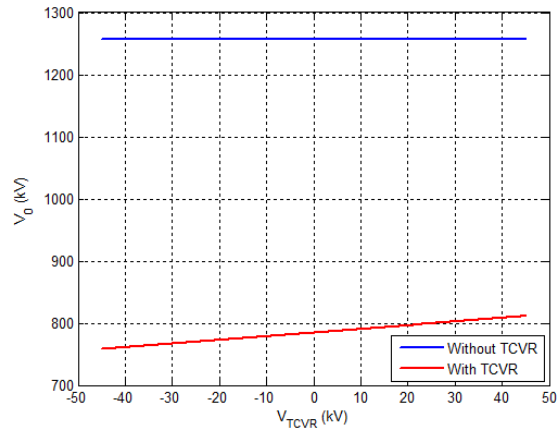

(c)

Figure 8. Impact of V_{TCVR} on Voltage Symmetrical Components of the Line:
 a). $V_1 = f(V_{TCVR})$, b). $V_2 = f(V_{TCVR})$, c). $V_0 = f(V_{TCVR})$

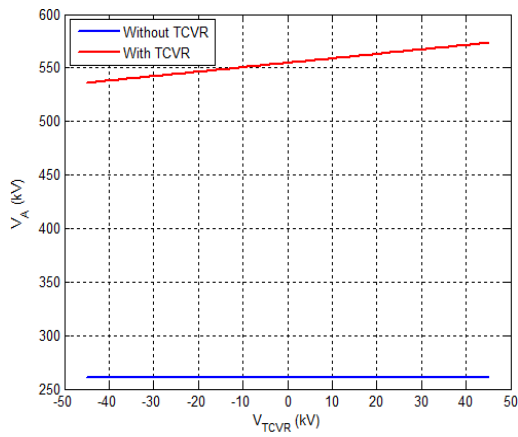

(a)

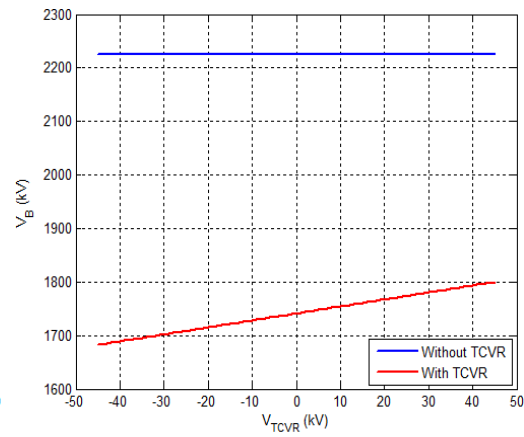

(b)

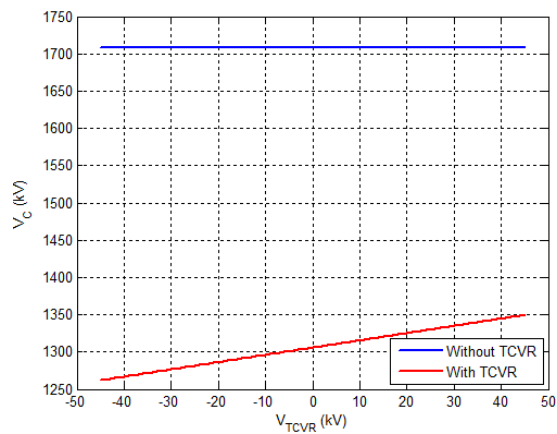

(c)

Figure 9. Impact of V_{TCVR} on Transmission Line Voltages:
 a). $V_A = f(V_{TCVR})$, b). $V_B = f(V_{TCVR})$, c). $V_C = f(V_{TCVR})$

In Figures 8.a, b, c, when using TCVR, increasing V_{TCVR} leads to an increase in the magnitude of each of the three voltage symmetrical components, though less increment is exhibited by the zero symmetrical component when compared with the

direct and negative components which both show rapid increment as V_{TCVR} increases. This is confirmed by equations (16), (18) and (20). It is also noticeable that the values of the direct and inverse voltage symmetrical components in the absence of TCVR are higher than their corresponding components while using TCVR in case of negative V_{TCVR} . On the other hand, in the case of positive V_{TCVR} , the magnitudes of the direct and inverse voltage symmetrical components in the presence of TCVR are higher than their corresponding components while not using TCVR. Across the whole range of V_{TCVR} , the zero voltage component in the presence of TCVR exhibits less magnitude than its magnitude when TCVR is not used.

In Figures 9.a, b, c, in the presence of TCVR, it is obvious that increasing V_{TCVR} leads to a corresponding increase in the magnitude of the voltage of each of the three phases. Across the whole range of V_{TCVR} , the magnitudes of phase voltages of *B* and *C* in the absence of TCVR are higher than their corresponding magnitudes when using TCVR. The opposite is exhibited for the voltage of phase *A* that shows a significant increase in magnitude when using TCVR which can be regarded as an advantage of using TCVR.

5. Conclusions

The paper highlighted the impact of using TCVR on the short-circuit parameters in case of a ground fault, in the presence of a fixed fault resistance, for a 400 kV transmission line installed between two substations in northern Algerian power system.

This research was focused on analyzing the effect of the voltage controlled by TCVR, whether positive or negative, on the following parameters: symmetrical current components, transmission line currents, voltage symmetrical components, and transmission line voltages. Analytical results based on symmetrical components method were presented and verified by simulations which showed perfect agreement.

The obtained simulation results concluded the significant impact of TCVR controlled voltage on short-circuit parameters of the ground fault, which varied between minimum and maximum values as a function of the positive and negative operation modes of the installed TCVR voltage. They also highlighted the advantages of using TCVR as a novel FACTS device particularly under fault conditions.

The paper proposes that off-line settings and coordination of relays are to be made while taking into consideration the effect of V_{TCVR} , especially in meshed power systems. This can be achieved by using artificial neural networks and heuristic approaches. It is also recommended to develop an automation system using optimization algorithms that will result in adaptive relay settings based on V_{TCVR} . This system can be adopted to determine the optimum settings of various protection devices and therefore helps to improve the quality of system operation.

References

- [1] N. D. Tleis, *Power Systems Modelling and Fault Analysis - Theory and Practice*, Published by Elsevier Limited, Oxford, United Kingdom, (2008)
- [2] C. A. Gross. *Fault Calculations in Power Systems Subject to Multiple Faults*. 22nd Southeastern Symposium on System Theory, (1990) March 11-13; Cookeville, USA, pp. 598-601.
- [3] V. C. Strezoski, and D. D. Bekut, *A Canonical Model for the Study of Faults in Power Systems*, IEEE Transactions on Power System, Vol. 6, No. 4, (1991), pp. 1493-1499.
- [4] K. Tanaka. *A Method of Mutual Coupling Effects of Multi Parallel Routes in the Presence of Unbalanced Faults*. Electrical Engineering in Japan, Vol. 136, No. 2, (2001), pp. 9-17.
- [5] F. M. Abouelenin. *A Complete Algorithm to Fault Calculation Due to Simultaneous Faults - Combination of Short Circuits and Open Lines*. IEEE 11th Mediterranean Electrotechnical Conference (MELECON), (2002) May 7-9; Cairo, Egypt, pp. 522-526.

- [6] J. H. Teng. Systematic Short Circuit Analysis Method for Unbalanced Distribution Systems. IEE Proc. Generation, Transmission and Distribution, Vol. 152, No. 4, (2005), pp. 549-455.
- [7] R. K. Gajbhiye, P. Kulkarni, and S. A. Soman. Analysis of Faulted Power Systems in Three Phase Coordinates - A Generic Approach. IEEE International Power Engineering Conference (IPEC), (2005) November 29 - December 2; Singapore, pp. 1052-1057.
- [8] H. H. El-Tamaly, and H. A. Ziedan. Fault Current Calculations as Influenced by Mutual Effect between Parallel Lines. Electrical Power Component System, Vol. 35, No. 9, (2007), pp. 1007-1025.
- [9] B. R. Bhalja, and R. P. Maheshwari. High Resistance Faults on Two Terminal Parallel Transmission Line: Analysis, Simulation Studies, and An Adaptive Distance Relaying Scheme. IEEE Transactions on Power Delivery, Vol. 22, No. 2, (2007), pp. 801-812.
- [10] P. L. Buccheri, and S. Mangione. Analysis of Ground Fault Current Distribution Along Nonuniform Multi-Section Lines. Electric Power Systems Research, Vol. 78, (2008), pp. 1610-1618.
- [11] A. Kalantari, and S. M. Kouhsari. An Exact Piecewise Method for Fault Studies in Interconnected Networks. International Journal of Electrical Power and Energy Systems, Vol. 30, No. 3, (2008), pp. 216-225.
- [12] J. Talaq. Fault Calculations using Three Terminal Thevenin's Equivalent Circuit. International Journal of Electrical Power and Energy Systems, Vol. 33, No. 8, (2011), pp. 1462-1469.
- [13] Y. H. Song, and A. T. Johns, Flexible AC Transmission System (FACTS), Published by IEE, Power and Energy Series 30, United Kingdom, (1999)
- [14] S. Gerbex, R. Cherkaoui, and A. J. Germond. Optimal Location of Multi-Type FACTS Devices in a Power System by Means of Genetic Algorithms. IEEE Transactions on Power Systems, Vol. 16, No. 3, (2001), pp. 537-544.
- [15] E. Ghahremani, and I. Kamwa. Maximizing Transmission Capacity Through a Minimum Set of Distributed Multi-Type FACTS. IEEE Power and Energy Society General Meeting, (2012) July 22-26; San Diego, USA, pp. 1-8.
- [16] N. G. Hingorani, and L. Gyugyi, Understanding FACTS Concepts and Technology of Flexible AC Transmission Systems, Published by IEEE Press, New York, USA, (1999)
- [17] C. L. Fortescue. Method of Symmetrical Coordinates Applied to the Solution of Polyphase Networks. Transactions of AIEE, Vol. 37, (1918), pp. 1027-1140.
- [18] J. Schlabach, Short-Circuit Currents, second edition, Published by Institution of Engineering and Technology (IET), London, United Kingdom, (2008)
- [19] S. Jamali, and H. Shateri. Impedance based Fault Location Method for Single Phase to Earth Faults in Transmission Systems. 10th IET International Conference on Developments in Power System Protection (DPSP), (2010) 29 March - 1 April; Manchester, United Kingdom, pp. 1-4.
- [20] J. L. Blackburn, and A. F. Sleva, Symmetrical Components for Power Systems Engineering, second edition, Published by CRC Press, London, United Kingdom, (2011)
- [21] M. Zellagui, H. A. Hassan, and A. Chaghi. Short-Circuit Calculations for a Transmission Line in the Algerian Power Network Compensated by Thyristor Controlled Voltage Regulator. Journal of Electrical and Electronics Engineering (JEEE), Vol. 7, No. 2, (2014), pp. 43-48.
- [22] Sonelgaz Group, Topology of Electrical Transmission Networks High Voltage, Algerian Company of Electrical Transmission, Algeria, (2013)

Authors



Mohamed Zellagui, Doctor and researcher in power systems in the Department of Electrical Engineering, University of Batna in Algeria. He received the engineering degree (Honors with first class) and M.Sc. degree in Electrical Engineering (Power System) from the Department of Electrical Engineering, University of Constantine, Algeria in 2007 and 2010, respectively. He received Doctor Degree in Power Systems from the Department of Electrical Engineering, University of Batna, Algeria in 2014. He is a member of LSP-IE research laboratory at Batna University, Algeria. In 2012, Dr. Zellagui obtained the national award for the best PhD student in science and technology. He has membership at International Association of Engineers (IAENG), Institute of Electrical and Electronics Engineers (IEEE), Power and Energy Society (PES), Smart Grid Community (SGC) and The Institute of Engineering and Technology (IET). He is a Senior Member of the Universal

Association of Computer and Electronics Engineers (UACEE), International Scientific Academy of Engineering & Technology (ISAET) and International Association of Computer Science and Information Technology (IACSIT). He is on the Editorial Board Member of the Journal of Electrical and Electronics Engineering (JEEE), International Journal of Electronic and Electrical Engineering (IJE) and Canadian Journal on Electrical and Electronics Engineering (JEEE). He serves as a reviewer for the International Journal of Engineering (IJE), Electric Power Components and Systems (EPCS), Journal of Energy and Power (JEP), and Advances in Electrical and Electronic Engineering (AEEE). His research interests include power systems protection, power electronics, short-circuit calculations, distance relays, overcurrent relays, renewable energy, and FACTS devices.



Heba Ahmed Hassan, she received her B.Sc. and M.Sc. with Distinction First Honors degree from Electrical Power and Machines Department, Faculty of Engineering, Cairo University, Egypt, in 1995 and 1999, respectively. She obtained her Ph.D. degree in Electrical Engineering from the University of Ulster, U.K, in 2004 when she was selected to present her Ph.D. work at the House of Commons, Parliament House, Westminster, London, UK. She joined Dhofar University, Salalah, Sultanate of Oman in 2008 where she was promoted to several senior leadership positions. She was the Acting Dean and Assistant Dean of College of Engineering, Dhofar University. Currently, she is an academic member of the Quality Assurance Unit of Dhofar University. She is also the university representative at Oman Quality Network (OQN) and Oman Academic Accreditation Authority (OAAA). She has been appointed to OAAA's Register of External Reviewers in June 2014.

Dr. Hassan is a full-time faculty (2005-present) in Electrical Power and Machines Department, Cairo University, currently on leave. She was an Academic Visitor at the Imperial College, London, UK (1998), a Teaching and Research Assistant at the University of Ulster, UK (2001-2005), and a part-time faculty at many respectable private engineering universities in Egypt (2005-2008). During that period, she worked as a quality auditor for the Quality Assurance and Accreditation Project (QAAP) and a consultant for several Egyptian MoHE development projects which were all financed by the International Bank for Reconstruction and Development (IBRD).

She co-supervised 2 M.Sc. Students, Faculty of Engineering, Cairo University (2005-2012). Dr. Hassan was selected by reputable universities in India as an External Ph.D. Examiner and as a Keynote Speaker in several international conferences. She was appointed by the Omani MoHE as a Reviewer of newly submitted academic programs. Dr. Hassan is a Senior IEEE member (SMIEEE), an IET Member (MIET), an Associate Fellow of the Higher Education Academy-UK (AFHEA), and a Certified Associate Academic Trainer by the International Board of Certified Trainers (IBCT) who conducted many

training programs for academic staff on effective teaching and assessment. She is the Chief Editor of two international referred journals in the field. She is also serving as an Associate Editor, an Editorial Board Member, and a Reviewer for many international journals and conferences in power engineering. She has always been a member of IEEE societies such as Power and Energy Society (PES), Control Systems Society (CSS), and Women in Engineering (WIE). Dr. Hassan research interests include electrical power systems stability and control, FACTS modeling, optimal and robust adaptive control, and quality of higher education related studies.



Abdelaziz Chaghi, Professor in the Department of Electrical Engineering, University of Batna, Algeria. He received his engineering degree from the University of Oran, Algeria in 1980, and M.Sc. from Manchester University, United Kingdom (UK) in 1984. He received Doctor Degree in Power Systems from Batna University, Algeria in 2004. He is also responsible for the research team of “power quality in distribution power systems” at LSP-IE research laboratory at University of Batna, Algeria. Professor Chaghi has published more than 50 papers in reputable international journals and conferences. His research interests include power systems optimization, power electronics, renewable energy, harmonics, power flow, voltage stability and FACTS devices.