

A 10 Gb/s Equalizer in 0.18 μ m CMOS Technology for High-Speed SerDes

Mingke Zhang and Qingsheng Hu

Institute of RF- & OE-ICs, Southeast University, Nanjing, 210096, China
mingke.zhang@hotmail.com

Abstract

A 10 Gb/s equalizer consisting of analog equalizer and two-tap half-rate decision feedback equalizer (DFE) in 0.18 μ m CMOS has been designed. By employing capacitive degeneration and inductive peaking techniques, the analog equalizer achieves large boosting. The pipelined half-rate architecture is used to improve the transmitted data rate in DFE with a small increase in area. Measurement results show that the distorted signal is well recovered by this equalizer and consumes 27 mW with the supply voltage of 1.8-V. The overall chip area including pads is 0.6 \times 0.7 mm².

Keywords: *analog equalizer; decision feedback equalizer (DFE); capacitive degeneration; inductive peaking; current mode logic (CML)*

1. Introduction

As wire-line communications systems continue to evolve to support ever-higher speeds, the channel inter-symbol interference (ISI) at high frequency is becoming more and more severe resulting in poor signal. There have been many reported methods to cancel the ISI. One of methods is using equalizer in receiver of systems. The equalizer in receiver can also be divided into two types: linear equalizer (LE) and decision feedback equalizer (DFE). LE can eliminate both pre-cursor and post-cursor ISI and is simpler in structure compared to DFE, but LE may increase noise and crosstalk. The DFE can eliminate post-cursor ISI without amplifying noise and crosstalk. However it may introduce the problem of error propagation [1-3]. From above viewpoint, this paper presents a 10 GB/s equalizer consisting of a linear equalizer and a nonlinear DFE in receiver for better equalization performance.

2. The Proposed Equalizer

In applications, there are also two typical linear equalizers: discrete-time FIR filter (FFE) and continuous time analog filter (analog equalizer). However, the implementation of FIR filter requires analog delay elements [3], which make them less practical, especially at higher data rates. On the other hand, alternatives to FIR filters include conventional high-frequency boost circuits that have a rational transfer function [4]. The locations of poles and zeros could be adjusted to fit a desired transfer function to arbitrary accuracy. More important, the analog high-frequency boost circuit is employed in our design for its simplicity of implementation. Thus, this paper proposed is a 2-tap half-rate DFE combined with a analog equalizer in Figure 1 (a).

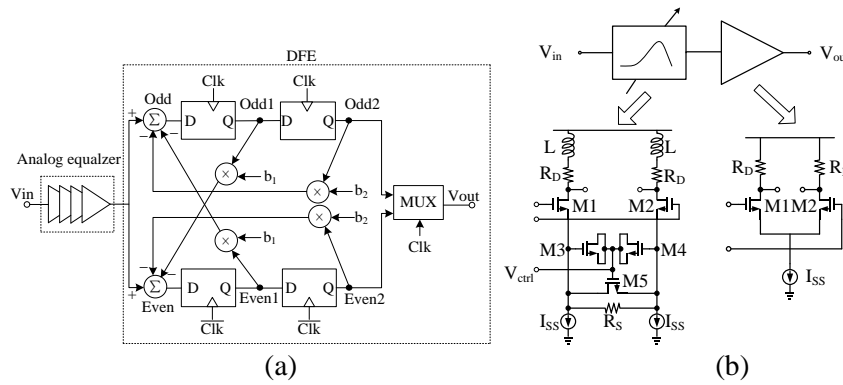

Figure 1. (a) Block Diagram of the Proposed Equalizer. (b) The Circuit of Analog Equalizer

3. Circuit Design

3.1. Analog Equalizer

Shown in Fig.1 (b), the analog equalizer intersperses a peaking stages with a gain stages to provide a boost factor of about 10 dB at 10 GHz. The peaking stage in the equalizer path employs degeneration capacitance and inductive shunt peaking load to give a large boosting and high gain [5]. In the Figure, nMOS transistors M3 and M4 act as degeneration capacitance, nMOS transistors M5 acts as a variable degeneration resistance along with M3 and M4, where the boost range and the gain of the LE can be adjusted by changing the control voltage. As the control voltage rises, the on-resistance M5 of falls and so does the capacitance of M3 and M4, raising the magnitude of the zero.

3.2. Decision Feedback Equalizer (DFE)

A CML based summer, master-slave D flip-flop (MSDFF) and multiplexer (MUX) are employed in this DFE due to their advantage of high speed, shown as Fig.2. With the function of slicer and delay element in DFE, D flip-flop is one of the most critical components since it should work as fast as possible. The optimization of DFF is usually performed by reducing the sizes of the tracking transistors M1, M2, cross-coupled transistors M3, M4 and clock transistors M5, M6. The size, however, can not be reduced too small. If it is reduced below a certain critical size, the cross-coupled pair will not latch. The sizes of tracking transistors M1, M2 and clock transistors M5, M6 are not also too small, since these differential pairs need to be large enough to switch the current correctly [6].

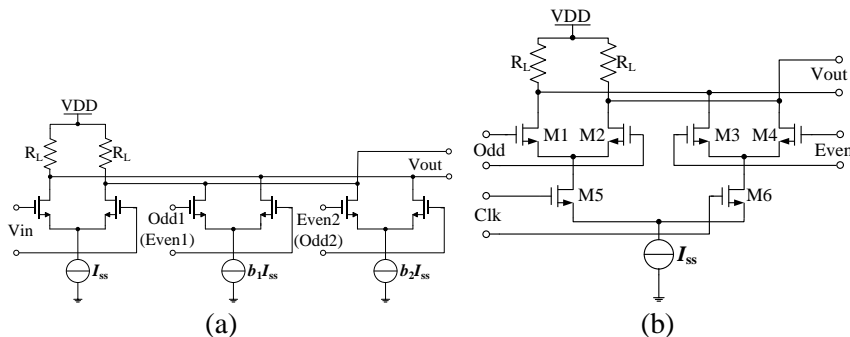

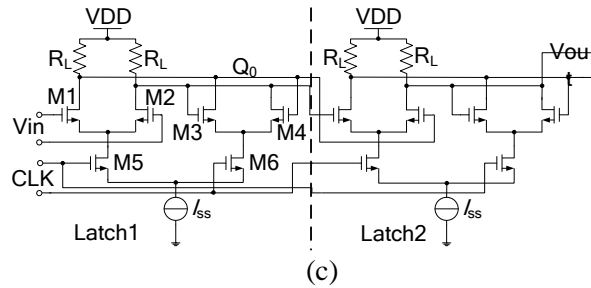
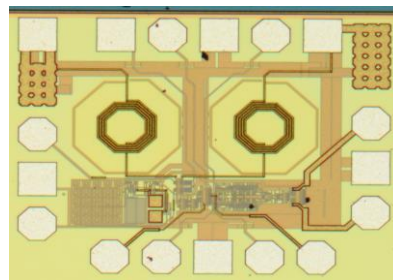

Figure 2. The CML-based Circuit. (a) Summer; (b) MUX; (c) MSDFF

4. Measurement Results

The proposed equalizer has been designed and fabricated using 0.18 μm CMOS technology. Fig. 3(a) shows the photograph of the equalizer. The overall chip area including pads is 0.6 \times 0.7 mm². Fig.3(b), (c) gives the measured eye diagrams of 10 Gb/s PRBS data before and after the equalizer, respectively. From the figure, we can see that the majority of the ISI is removed, providing a horizontal eye opening of 0.62UI. This illustrates that the combined equalizer works well and is able to reduce ISI from the received data.



(a)

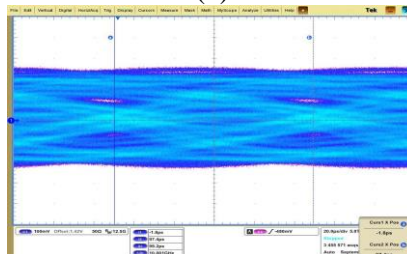

(b)

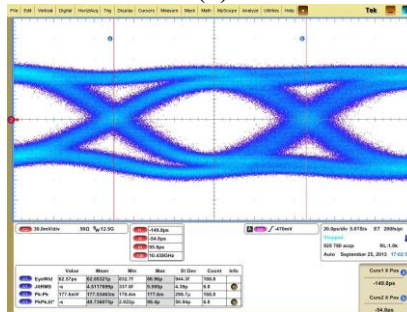

(c)

Figure 3. (a) Photomicrograph of the Equalizer. (b) Measured Eye Diagram Before Equalization. (c) Measured Eye Diagram after Equalization

5. Conclusion

In this paper, a 10 Gb/s equalizer is realized in TSMC 0.18 μ m CMOS technology. The equalizer composed of an analog equalizer and 2-tap DFE enables error-free NRZ signaling over a long backplane channel. Measurement results show that the equalizer chip can operate at data rates up to 10 Gb/s with an improved horizontal eye openings of 0.62 UI. The equalizer including pads occupies 0.6 \times 0.7 mm² and consumes 27 mW from 1.8-V supply voltage.

Acknowledgements

The authors would like to thank Agilent Open Library for providing the test equipment.

References

- [1] T. O. Dickson, J. F. Bulzacchelli and D. J. Friedman, "A 12 Gb/s 11 mW half-rate sampled 5-tap decision feedback equalizer with current integrating summers in 45 nm SOI CMOS technology", In: IEEE J. Solid-State Circuits, vol. 44, (2009), pp. 1298-1305.
- [2] S. Song and V. Stojanovic, "A 6.25 Gb/s Voltage-Time Conversion Based Fractionally Spaced Linear Receive Equalizer for Mesochronous High-Speed Links", In: IEEE J. Solid-State Circuits, vol. 46, (2011), pp. 1183-1197.
- [3] T. Beukema, M. Sorna and K. Selander, "A 6.4-Gb/s CMOS SerDes Core with feed-forward and decision-feedback equalization", In: IEEE J. Solid-State Circuits, vol. 40, pp. 2633-2645, (2005).
- [4] J. E. C. Brown and P. J. Hurst, "A 35 Mb/s Mixed-Signal Decision-Feedback Equalizer for Disk Drivers in 2- μ m CMOS", In: IEEE J. Solid-State Circuits, vol. 31, (1996), pp. 1258-1266.
- [5] S. Ibrahim and B. Razavi, "Equalization and Clock and Data Recovery Techniques for 10-Gb/s CMOS Serial-Link Receivers", In: IEEE J. Solid-State Circuits, vol. 42, (2007), pp. 1999-2011.
- [6] S. Ibrahim and B. Razavi, "Low-Power CMOS Equalizer Design for 20-Gb/s Systems", In: IEEE J. Solid-State Circuits, vol. 46, (2011), pp. 1321-1336.

Authors

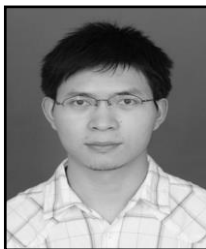

Mingke Zhang, he was born in Xuancheng, China, in 1985. He received the B.S. degree in communication engineering from East China Jiao tong University, Nanchang, China, in 2008. He is currently pursuing the Ph.D. degree in the Graduated Institute of RF- & OE-ICs in Southeast University, Nanjing, China.

His research interests include phase-locked loops, high-speed SerDes and backplane transceivers.



Qingsheng Hu, she was born in Hefei, China, in 1964. She received the circuits and systems doctoral degree from Shanghai Jiao Tong University, Shanghai, China in 1997. Then she engaged in postdoctoral research in communications and electronics department of China Science and Technology University. In 1999, she joined Nanjing Institute of ZTE, where she engaged in research and development of communications products. In 2002, she engaged in postdoctoral research in electrical and electronic engineering and computer engineering department of Hong Kong Science and Technology University. In 2003, she joined at the radio engineering department of Southeast University.