

## Fuzzy State Feedback Control for Way-Point Tracking of Autonomous Underwater Vehicle

Dong H. Shin<sup>1</sup>, Soon T. Kwon<sup>2</sup>, Sang H. Park<sup>3</sup> and Moon G. Joo<sup>1</sup>

<sup>1</sup>Dept. Information and Communications Eng., Pukyong Nat. Univ., Busan, Korea

<sup>2</sup>Dept. Unmanned Vehicle System, Hanwha R&D Center, Daejeon, Korea

<sup>3</sup>Dept. Electronic Engineering, Pukyong Nat. Univ., Busan, Korea  
gabi@pknu.ac.kr

### Abstract

In this paper, we propose a design method of the tracking and controlling AUV(autonomous underwater vehicle) that has wide range of velocity. The state feedback controllers are designed according to determined surge speed and then a fuzzy controller is designed in a way that the outputs of the state feedback controller are combined by the surge speed of AUV, so that when the surge speed changes, the AUV control becomes stable. By simulation using Matlab/Simulink, the performance of the proposed controller is shown to be efficient.

**Keywords:** AUV, fuzzy, way point tracking, state feedback, line of sight

### 1. Introduction

Recently, the demand for AUV (autonomous underwater vehicle) is growing steadily with the development of the marine material and for the military purposes. REMUS [1], MAYA [2], STARFISH [3], and ISiMI [4] are representative AUVs of USA, India, Singapore, and S. Korea, respectively.

And there have been many researches about the various methods of controlling AUVs, where assume the constant velocity of AUV using state feedback control [5] or regard the variation of velocity as disturbance using sliding mode control [6]. But, there will be disadvantages in implementing various tasks if we operate only in the constant velocity in the marine status where the many unseen variables make a big effect. Thus, there will be need for a design of the controller that can cope with the change of the velocity over the endurable level of disturbance.

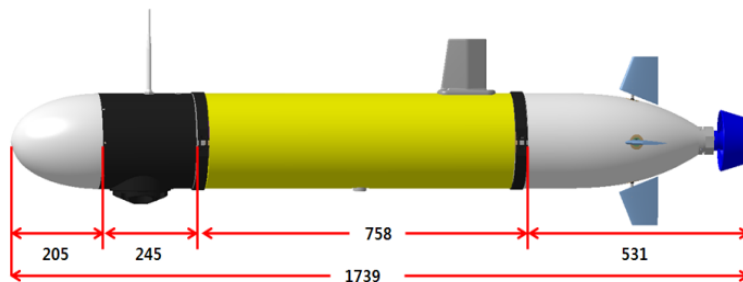


Figure 1. Appearance of AUV

Authors are implementing an AUV [7] using GPS, IMU, DML and the depth sensor to measure the location and the posture of the underwater robot. It has 4 rudders and 1 thruster to control the movement as shown in the Figure 1.

## 2. Designing AUV Controller

### 2.1. The Linear Model for Depth Control of AUV

With notations and the values of the variables in [1], when surge speed is constant, the depth system of AUV is linearized into the linear system [8, 9] with 4 status variables as Eq. (1), where  $w, q, z, \theta$  and  $\delta_s$  represent heave, pitch rate, depth, pitch angle, and the elevating angle of stern, respectively.  $U$  is the surge speed and  $w_d = q_d = \dot{z}_d = \theta_d = 0$ .

$$\dot{x}_e = \begin{bmatrix} 78.5 & 1.93 & 0 & 0 \\ 1.93 & 8.33 & 0 & 0 \\ 0 & 0 & 1 & 0 \\ 0 & 0 & 0 & 1 \end{bmatrix}^{-1} \begin{bmatrix} -66.6 & 43U - 9.67 & 0 & 0 \\ 30.7 & -6.87 & 0 & -5.77 \\ 1 & 0 & 0 & -U \\ 0 & 1 & 0 & 0 \end{bmatrix} x_e + \begin{bmatrix} -0.15 \\ -1.03 \\ 0 \\ 0 \end{bmatrix} \quad (1)$$

$$x_e = [w - w_d, q - q_d, z - z_d, \theta - \theta_d]^T$$

Here,  $z_d$  represents the target depth of AUV and the assumption of  $\dot{z}_d = 0$  is satisfied when the targeted depth is given as the step function. Assuming the velocity of AUV as  $1.2m/s, 2.4m/s$ , and  $3.6m/s$  respectively, we have three linear models.

By the pole placement technique, we set every pole on the left half plane of complex number plane as Table 1 for stability. Since the control system using computer is a discrete time system using 0.1 second of sampling time, the corresponding pole position in discrete time domain is computed by  $z^* = e^{s^*T}$ , where T is the sampling time and set to 0.1 sec.

**Table 1. State Feedback Controllers for Fixed Surge Speed**

Surge (m/s)	Continuous time controller	Desired pole( $s^*$ )	Desired pole( $z^*$ )
1.2	$\delta_{s1}(t) = -Kx_e(t)$	(-0.5, -0.5, -2, -4)	(0.95, 0.95, 0.82, 0.67)
2.4	$\delta_{s2}(t) = -Kx_e(t)$	(-0.7, -0.7, -3, -6)	(0.93, 0.93, 0.74, 0.55)
3.6	$\delta_{s3}(t) = -Kx_e(t)$	(-1.2, -1.2, -2, -6)	(0.89, 0.89, 0.82, 0.55)

To get the feedback gains in discrete time domain, system Eq. (1) is converted by using Matlab. By the pole placement again, we have the discrete time controller with T=0.1 as Table 2.

**Table 2. Discrete Time State Feedback Controllers for Each Surge Speed**

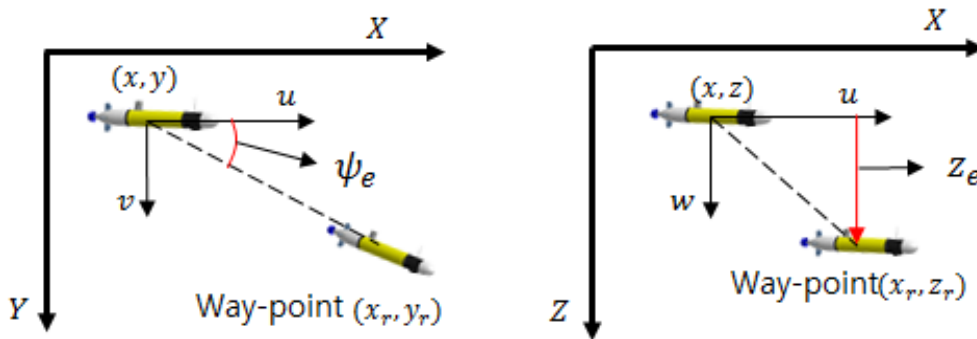
Surge (m/s)	Discrete time controller	State feedback gain, K
1.2	$\delta_{s1}(k) = -Kx_e(k)$	$[-3.90 \quad -3.51 \quad 0.89 \quad -3.82]$
2.4	$\delta_{s2}(k) = -Kx_e(k)$	$[-0.89 \quad -1.39 \quad 0.41 \quad -2.78]$
3.6	$\delta_{s3}(k) = -Kx_e(k)$	$[-0.24 \quad -0.64 \quad 0.22 \quad -1.67]$

## 2.2 The Linear Model for Steering Control of AUV

Then surge speed is constant, the movement of the AUV on the horizontal plane can be linearized as the linear system having 3 status variables as Eq. (2), where  $v, r, \psi$  and  $\delta_r$  represent sway speed, yaw rate, and the rudder angle, respectively. We assume that  $v_d = r_d = \dot{\psi}_d = 0$ .

$$\dot{x}_e = \begin{bmatrix} 43U + 35.5 & -1.93 & 0 \\ -1.93 & 8.33 & 0 \\ 0 & 0 & 1 \end{bmatrix}^{-1} \begin{bmatrix} -34.32 & -80.78U & 0 \\ -28.80 & -2.40 & 0 \\ 0 & 1 & 0 \end{bmatrix} x_e + \begin{bmatrix} 0.15 \\ -1.03 \\ 0 \end{bmatrix} \delta_r \quad (2)$$

$$x_e = [v - v_d, r - r_d, \psi - \psi_d]^T$$



**Figure 2. Steering Angle Error by Line of Sight Algorithm and Depth Error**

The desired steering angle is computed by the line of sight algorithm in Figure 2, and it is given by

$$\psi_d = \arctan((y_r - y) / (x_r - x)).$$

Through the same procedure, we have three discrete time state feedback controllers as Table 3 and Table 4.

**Table 3. State Feedback Controllers for Fixed Surge Speed**

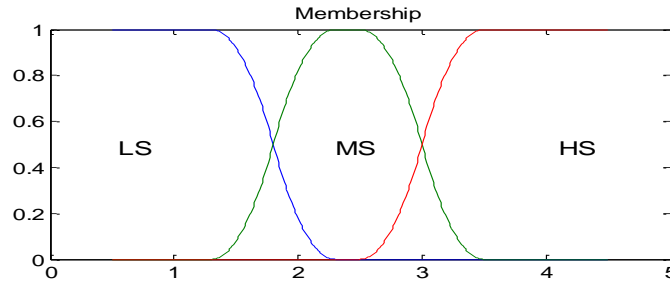
Surge (m/s)	Continuous time controller	Desired pole( $s^*$ )	Desired pole( $z^*$ )
1.2	$\delta_{r1}(t) = -Kx_e(t)$	(-1.1, -1.1, -5)	(0.90, 0.90, 0.61)
2.4	$\delta_{r2}(t) = -Kx_e(t)$	(-2.2, -2.2, -6)	(0.80, 0.80, 0.55)
3.6	$\delta_{r3}(t) = -Kx_e(t)$	(-3.2, -3.2, -9)	(0.73, 0.73, 0.41)

**Table 4. Discrete Time State Feedback Controllers for each Surge Speed**

Surge (m/s)	Discrete time controller	State feedback gain, K
1.2	$\delta_{r1}(k) = -Kx_e(k)$	[3.3117 -4.3174 -4.1515]
2.4	$\delta_{r2}(k) = -Kx_e(k)$	[1.5831 -1.3876 -2.2333]
3.6	$\delta_{r3}(k) = -Kx_e(k)$	[1.0140 -0.8298 -1.7339]

### 2.3 Application of the Fuzzy System

We configure the membership function of surge speed as Figure 3, where linguistic variables LS, MS, and HS represent low speed, medium speed, and high speed, respectively.



**Figure 3. Fuzzy Membership Function**

The input of the fuzzy system is the surge speed and the output is the rudder angle and the stern angle of the AUV. The purpose of the fuzzy system is to broaden the range of surge speed successfully managed by the given control scheme. The fuzzy rules are

$$R^1 : \text{IF surge is LS THEN } \delta_s \text{ is } \delta_{s1} \text{ and } \delta_r \text{ is } \delta_{r1}$$

$$R^2 : \text{IF surge is MS THEN } \delta_s \text{ is } \delta_{s2} \text{ and } \delta_r \text{ is } \delta_{r2}$$

$$R^3 : \text{IF surge is HS THEN } \delta_s \text{ is } \delta_{s3} \text{ and } \delta_r \text{ is } \delta_{r3}$$

Using singleton fuzzifier, center average defuzzifier, and sum-product inference, the output becomes

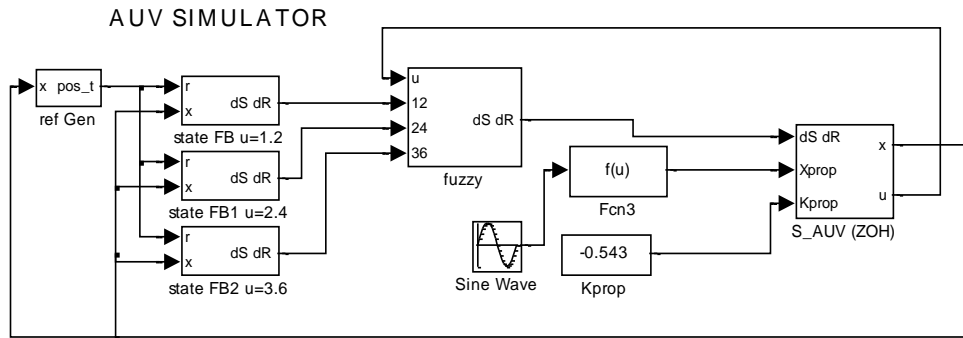
$$\delta_s = \frac{\sum_{j=1}^N w_j \delta_{sj}}{\sum_{j=1}^N w_j}, \quad \delta_r = \frac{\sum_{j=1}^N w_j \delta_{rj}}{\sum_{j=1}^N w_j}, \quad (3)$$

where  $w_j$  is the fitness value for the  $j$ -th rule.

### 3. Simulation

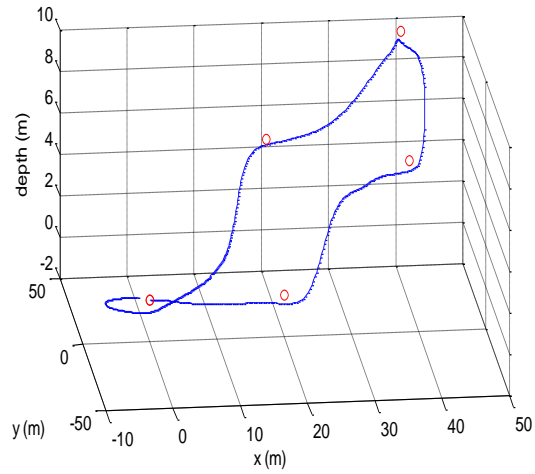
The simulation is performed by using the MATLAB/Simulink. The proposed controller is the discrete system of 10Hz, and ode45 is used as the translator for the simulation. In the measurement of the directional velocity and angular velocity of the AUV, we include random noise between  $\pm 0.005m/s$ ,  $\pm 15^\circ/s$ , and assume the maximum operating speed of the rudders and sterns is  $60^\circ/s$  within  $\pm 40^\circ$ .

The whole composition of the state feedback controller where the fuzzy theory is applied is as in the Figure 4. We assume that the torque is maintained at  $-0.543Nm$ . To illustrate the performance of the proposed controller dramatically, we add sine wave disturbance to the propulsion which varies between 1.5m/s and 4m/s.

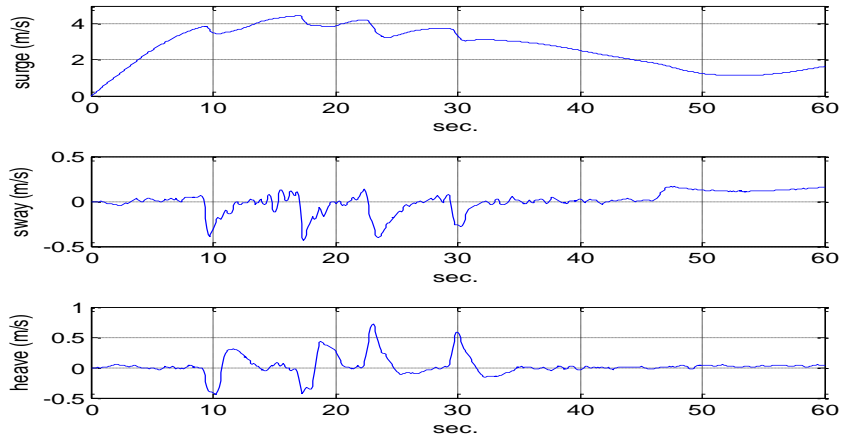


**Figure 4. The Composition of the State Feedback Controller and the Fuzzy System**

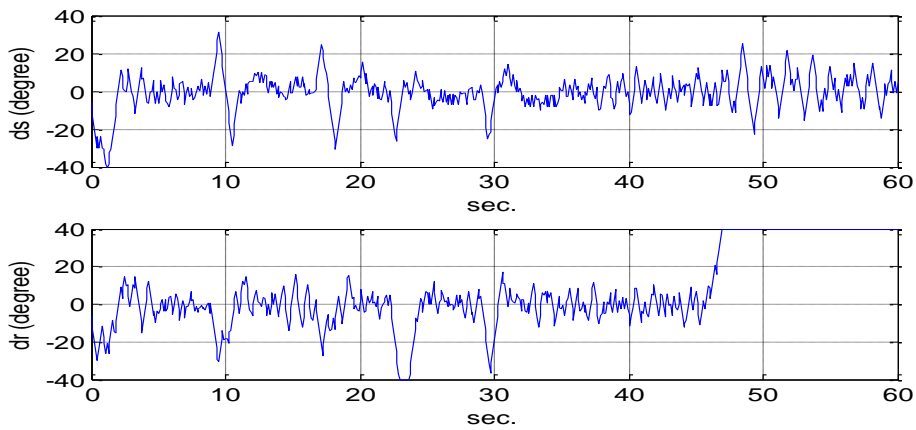
Figure 5 is the result of the simulation that designate the points (0, 0, 0) (20, 0, 0) (40, 20, 5) (40, 40, 10) (20, 40, 5) (0, 0, 0), when the change the velocity is between 1.5 m/s and 4m/s. We can see that the AUV passes through all the targeted points and returns back to its original place. The directional velocity of AUS is shown in Figure 6, and the surge speed is between 1.5 m/s and 4 m/s.



**Figure 5. AUV's Moving Route**



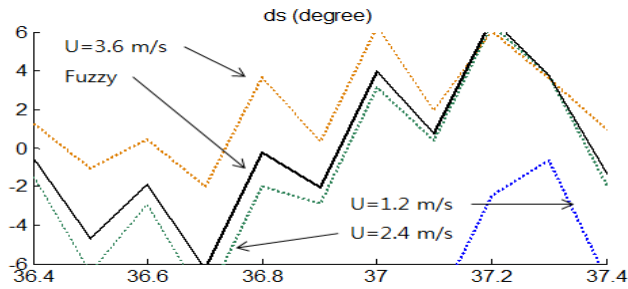
**Figure 6. AUV's Directional Speed**



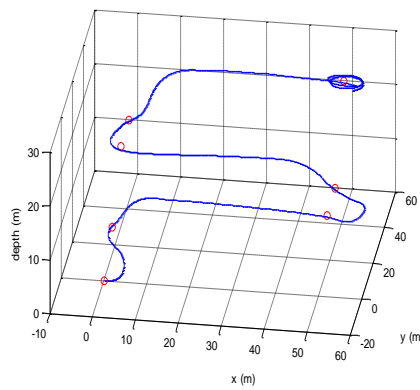
**Figure 7. The Angle of Rudder and Stern**

The controlled angle of rudder and stern granted to the AUV is as in the Figure 7. We can see that it is operated within the scope of  $\pm 40^\circ$ . Figure 8 is the magnified stern angle, where the dotted lines are the output of the state feedback controller before passing through the fuzzy controller, and the solid line is the output of the fuzzy system.

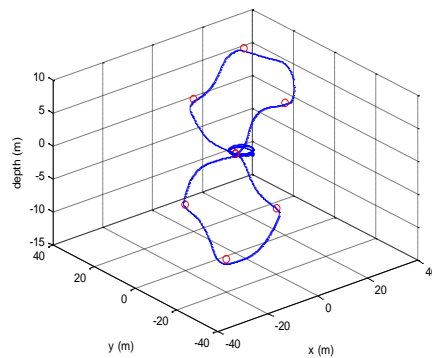
Figure 9 and Figure 10 are the control results for other way-points that show the feasibility of the proposed control scheme.



**Figure 8. The Output of each Controller**



**Figure 9. Zig-zag Trajectory of AUV**



**Figure 10. '8'-shape Trajectory of AUV**

For the comparison with other controller, a PD controller, a state feedback controller for a typical surge speed with 4 states, and a sliding mode controller are chosen. The way-points are (0, 0, 0), (0, 30, 0), (0, 50, -10), (20, 50, -10), (20, 0, -10), (40, 0, -10), (40, 50, -10), (60, 50, -10), (60, 0, -10), (80, 0, -15), (80, 50, -15), (100, 50, -10), (100, 0, -5), (0, 0, 0) to make a zig-zag trajectory.

The control output of the PD controller for the depth control is designed using the depth error and its pitch error, and for the steering, using the yaw angle. They are

$$\delta_s = 3.0e_z + 0.5\dot{e}_z + 7.0e_\theta + 0.0\dot{e}_\theta \quad (4)$$

$$e_z = z_d - z, \quad e_\theta = \theta_d - \theta$$

$$\delta_r = -2.0e_\psi - 0.5\dot{e}_\psi \quad (5)$$

$$e_\psi = \psi_d - \psi$$

and its control result is shown in Figure 11, where some of the way-points are approached by a few rotation around them. The control output of a state feedback [5] for the AUV is

$$\delta_s = 3.4411w - 2.2215q + 0.4922(z - z_d) - 1.9826\theta \quad (6)$$

$$\delta_r = 3.2880v - 4.1813r - 3.4995(\psi - \psi_d) \quad (7)$$

and its control result is shown in Figure 12. And the control output of a sliding mode controller [10] for the AUV is

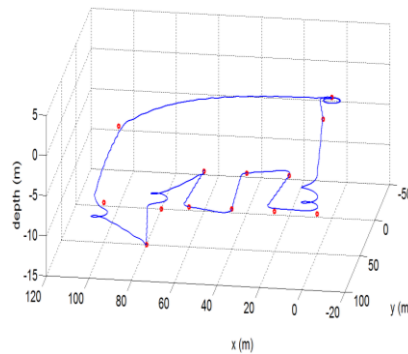
$$\delta_r = 0.8773w + 1.6005\theta + 0.0645\dot{z}_d - 0.0563 \tanh(10\sigma_z) \quad (8)$$

$$\sigma_z = -0.6996q + 0.1457(z - z_d) - 0.6996\theta$$

$$\delta_s = -3.1150v + 0.8415r - 0.4755\dot{\psi}_d + 0.2871 \tanh(10\sigma_{xy}) \quad (9)$$

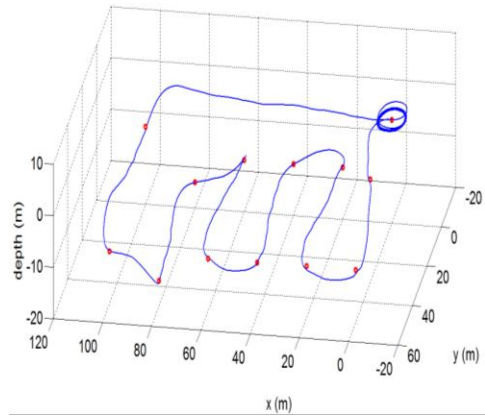
$$\sigma_{xy} = 0.0164v + 0.5610r + 0.8277(\psi - \psi_d)$$

and its control result is shown in Figure 13. Figure 14 shows the control result of the proposed controller. Figure 15 is the control efforts for each controller.

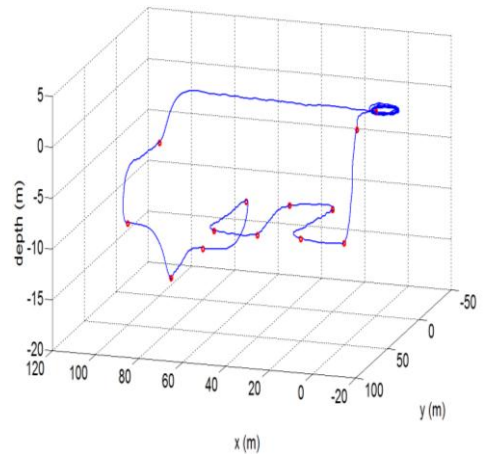


**Figure 11. Trajectory of PD Controller**

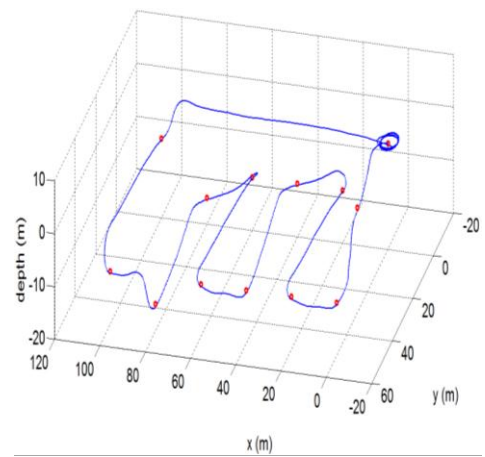




**Figure 12. Trajectory of State Feedback Controller**



**Figure 13. Trajectory of Sliding Mode Controller**



**Figure 14. Trajectory of Fuzzy Controller**

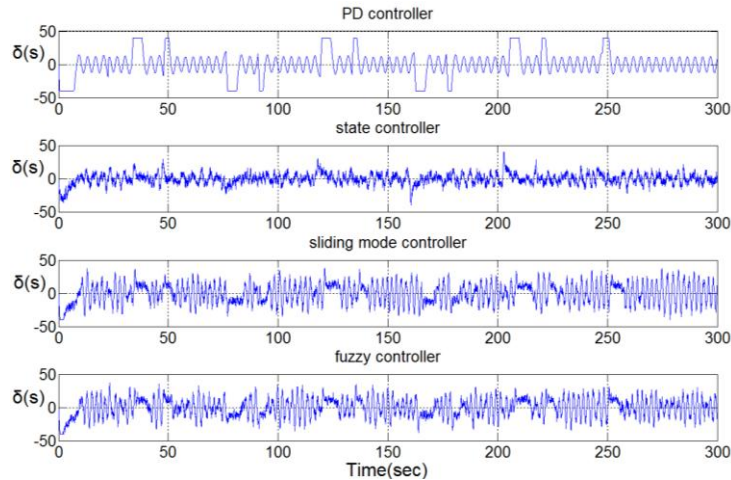


Figure 15. Steering Control Effort of each Controller

#### 4. Conclusion

We designed the status feedback controller for the pursuit of the way-points of the AUV, and in order to broaden the operating speed, we configured some different feedback gains according to the surge speeds by the pole placement technique in discrete time domain. And then, in order to schedule appropriate gains, we added the fuzzy system.

Matlab/Simulink simulation showed that the AUV passed through all the targeted points within the range of 1m error by the proposed controller.

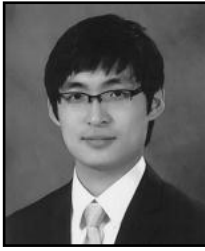
#### Acknowledgements

This work is the result of the "Human Resource Development Center for Economic Region Leading Industry" Project, supported by the Ministry of Education, Science & Technology (MEST) and the National Research Foundation of Korea (NRF).

#### References

- [1] T. Prestero, "Verification of a six-degree of freedom simulation model for the REMUS autonomous underwater vehicle", M. S. thesis, MIT/WHOI, (2001).
- [2] E. Desa, R. Madhan, P. Maurya, *et al.*, "The small MAYA AUV: Initial field results", Underwater World Publications, (2007).
- [3] E. Y. Hong, H. G. Soon and M. Chitre, "Depth control of an autonomous underwater vehicle, STARFISH", OCEANS 2010 IEEE-Sydney, (2010), pp. 1-6.
- [4] B. H. Jun, J. Y. Park, F. Y. Lee, P. M. Lee, C. M. Lee, K. Kim, Y. K. Lim and J. H. Oh, "Development of the AUV 'ISiMI' and a free running test in an ocean engineering basin", Ocean Eng'g, vol. 36, (2009), pp. 2-14.
- [5] S. T. Kwon, W. K. Baek, I. P. Kang, H. S. Choi and M. G. Joo, "A study on way-point tracking of AUV using state feedback", Journal of institute of control, robotics, and systems, vol. 14, (2012), pp. 1261-1272.
- [6] H. Zhou, K. Liu and X. Feng, "State feedback sliding mode control without chattering by construction Hurwitz matrix for AUV movement", IJAC, (2011), pp. 262-268.
- [7] S. T. Kwon, W. K. Baek and M. G. Joo, "Implementation of AUV test-bed", Future information technology, vol. 184, (2011), pp. 280-284.
- [8] T. I. Fossen, "Guidance and control of ocean vehicle", Jone Wiley & Sons, New York, (1994).
- [9] K. M. Fauske, F. Gustafsson and Ø. Hegrenæs, "Estimation of AUV dynamics for sensor fusion", Proc. the 10th Conf. Information Fusion, (2007), pp. 1-6.
- [10] S. T. Kwon, D. H. Shin and M. G. Joo, "Way-point tracking of AUV using sliding mode controller", The journal of Korean institute of information technology, vol. 10, (2012), pp. 17-22.

## Authors



**D. H. Shin**

He received the B. S. in Electronic, Computer and Telecommunication Engineering from Pukyong National University, Busan, Korea in 2012. His research interests include factory automation, embedded system, and unmanned vehicle systems.



**S. T. Kwon**

He received the B. S. in Electronic, Computer and Telecommunication Engineering, the M. S. in Telecommunication Engineering from Pukyong National University, Busan, Korea in 2010 and 2012, respectively. He is an associate research engineer at Hanwha corporation R&D center. His research interests include factory automation, embedded system, and unmanned vehicle systems.



**S. H. Park**

He received the B.S., M.S. and Ph.D. degrees in electronic engineering from Pohang University of Science and Technology (POSTECH), Kyungbuk, Korea, in 2004, 2007, and 2010, respectively. After his graduate work at the EMLAB of POSTECH, he joined the Faculty of Pukyong National University, Busan, Korea, where he is now an assistant Professor. His research interests are in the areas of radar target imaging and recognition, radar signal processing, target motion compensation, pattern recognition using artificial intelligence, and RCS prediction.



**M. G. Joo**

He received the B. S. in Electronics and Electric Engineering, the M. S. in Computer and Communications Engineering, and the Ph. D. in Electrical and Computer Engineering from Pohang University of Science and Technology, Pohang, Korea in 1992, 1994, and 2001, respectively. Dr. Joo was a senior researcher at Research Institute of Industrial Science and Technology, Pohang, Korea from 1996 to 2003. Since 2003, he is a professor of Information and Communications engineering at Pukyong National University, Busan, Korea. In 2007, he spent his sabbatical year researching at the Computer Science and Engineering Department, Wright State University, OH. His research interests include factory automation and intelligent control.

