

## Pre-processing and Step-size Adaptation for Performance Improvement in ADM

B K Sujatha<sup>1</sup>, Dr. P S Satyanarayana<sup>2</sup>, FIETE, and Dr. K N Haribhat<sup>3</sup>

<sup>1</sup>M S Ramaiah Institute of Technology, Bangalore

<sup>2</sup>B M S College of Engineering., Bangalore

<sup>3</sup>Nagarjuna College of Engineering and Technology, Bangalore

bksujatha08@gmail.com , pssvittala@yahoo.com , knhari.bhat@gmail.com

### Abstract

*Delta modulation plays a key role in data communication; the problem encountered in delta modulation is the slope over load error, which is inherent in the system. In order for the signal to have good fidelity, the slope-overload error needs to be as small as possible. Adaptive delta modulation reduces the slope over load error to a greater extent. ADM attempts to increase the dynamic range and the tracking capabilities of fixed step-size delta modulation. The adaptive algorithms adjust the step size (from a range of step sizes) to the power level of the signal and thus enhance the dynamic range of the coding system appreciably. This paper suggests a novel 1-bit Adaptive Delta Modulation technique for improving the signal-to-noise ratio (SNR) of Adaptive Delta Modulators (ADM). Various step-size algorithms are discussed and also their performance comparison is made. A new technique has also been discussed with a suitable pre-filer used for improving the SNR.*

**Keywords:** Adaptive Delta Modulation, Delta Modulation, A/D conversion, Pre-processing, Speech processing.

### 1. Introduction

Non-adaptive delta modulation is known by the name of Linear Delta Modulation (LDM). Linear Delta Modulation [1] uses a constant step size for all the signal levels. In designing a linear delta modulator, the step size and sampling rate are the main concern. The signal-to-granular noise ratio must be minimized so that the low level signal can be encoded. The signal-to-slope-overload distortion ratio must be minimized to encode the highest level signals. Minimizing these optimizes the performance of a linear delta modulator. The LDM suffers from a very limited dynamic range due to two types of errors, namely, the slope-overload noise and the granular noise as shown in Fig 1. Slope-overload occurs when the step size  $S$  is too small for the staircase approximation of the input  $x(n)$  to follow the steep segments of input waveform. In other words, slope-overload occurs when the rate of change of input exceeds the maximum rate of change in the feedback loop. Granular noise occurs when the step size is too large relative to slope characteristic of input waveform, thereby causing the staircase waveform to hunt around a relatively flat segment of the input waveform. Smaller the step size, smaller is the granular noise, but small step size increases the likelihood of slope-overload.

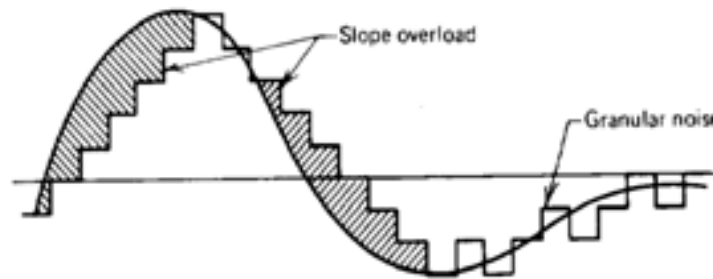

Figure 1. LDM and its characteristics

Analysis of LDM quantization noise have been carried out by several researchers. Important among them are the work of Van de weg [2] and Goodman [3] for granular noise and Greenstein [4] for the slope-overload.

O'Neal [5] has obtained a simple estimate of total resultant noise power when the variance of granular and overload noise are added together. But due to the non-linearity, an exact analysis has not been presented. However, an analysis reported by Slepian [6] gives an exact relationship between SNR and optimum step size for Gaussian signals with a (non-band limited) rational power spectrum. Other notable mathematical derivations in this subject are the SNR formulae as given by Tomozaw and Kaneko [7] and Johnson [8] for sinusoidal inputs.

Adaptive delta modulation (ADM) [9] reduces the slope-overload and granular distortions encountered in linear delta modulators (LDM) to a greater extent. In each of the step-size algorithms of adaptive delta modulators (ADM), the processor detects the pattern to see if the delta modulator is operating in the granular noise region, in which case it produces an alternating .....1010..... pattern, or in the slope over load region in which case it produces an all-1 or all-0 pattern. If the ADM senses a ...1010.... pattern, it decreases the step-size and if it senses .....1111.... or ....0000.... it increases the step-size. Different step-size adaptation algorithms changes the rate of change of step-size in different ways. A good amount of work has been done in this area using SONG[10] and modified ABATE[11] step-size algorithms. In the case of SONG algorithm if the output is alternatively ...1010... the step-size is minimum say  $S_0$ . If it is continuous 1's like 1111...11 or continuous zero's like 0000...00, the step-size adaptation increases the magnitude of step-size as  $S_0, 2S_0, 3S_0$ , etc., Modified ABATE algorithm is same as SONG but maximum step-size is limited to  $8S_0$ . In both SONG and modified ABATE algorithms, the rate of change of step-size in the slope- overload region is  $S_0$ .

A new algorithm is introduced where the rate of change of step-size in slope-overload region is made greater than  $S_0$ . This reduces slope-overload noise. It is shown that the performance can be further improved by pre-processing the input signal.

The proposed scheme is compared with SONG and modified ABATE algorithms considering sine wave and arbitrary speech sample with SNR as the performance criterion. The arbitrary sample speech waveform in the illustration is taken from the speech sound "i i i i" which is shown in Fig.2.

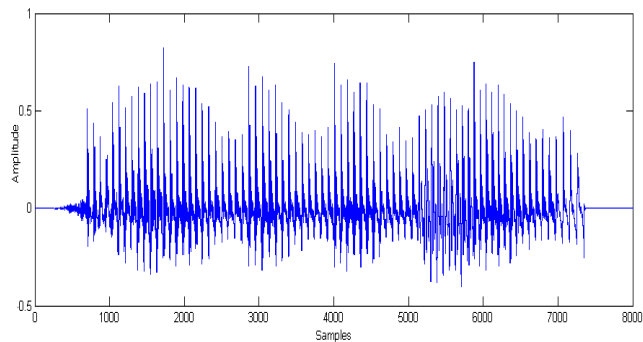

Figure 2. Sample speech signal 'iiii'

The organization of the paper is as follows which includes the experimental results. Section 2 discusses SONG and modified ABATE step-size adaptation algorithms. The proposed new step-size adaptation algorithm is presented in section 3. Comparisons with SONG, modified ABATE and the proposed algorithms are made in section 4. In section 5, the proposed ADM with pre-processing of message signal using an integrator is discussed. Section 6 summarizes the conclusions.

## 2. The existing step-size adaptations

### 2.1. SONG Algorithm

Let  $m(t)$  be the input signal and  $\hat{m}(t)$  be its staircase approximation. Let error,  $e(k) = m(t) - \hat{m}(t)$  at the  $k^{\text{th}}$  sampling instant.  $k = 0, 1, 2, 3, \dots$ .  $e(k)$  can be of positive or negative value. The  $k^{\text{th}}$  transmitted symbol is '1' if  $e(k) > 0$ , otherwise it is '0' if  $e(k) < 0$ . If  $e(k) = 0$ , either '1' or '0' can be transmitted.

The SONG algorithm used by NASA[12] produces the step-size  $S(k + 1)$  which minimizes the mean-square error between  $m(t)$  and  $\hat{m}(t)$ . In the implementation of the SONG system  $\pm 5$  V was the maximum signal level and the minimum step-size was  $S_0 = 10$  mV. The algorithm is illustrated in Fig 3. Here we see that as long as  $e(k)$  is of the same sign as  $e(k - 1)$  the magnitude of the new step-size  $S(k + 1)$  will exceed the magnitude of the old step-size  $S(k)$  by  $S_0$ , the minimum step-size. However, if  $e(k)$  and  $e(k - 1)$  differ in sign, the magnitude of  $S(k + 1)$  will be less than the magnitude of  $S(k)$  by the amount  $S_0$ . The equation describing the SONG algorithm is then

$$S(k + 1) = |S(k)|e(k) + S_0 e(k - 1) \quad (1)$$

The algorithm can also be written in terms of the following equation.

$$|S(k + 1)| = \begin{cases} |S(k)| + S_0 & e(k) = e(k - 1) \\ |S(k)| - S_0 & e(k) \neq e(k - 1) \end{cases} \quad (2)$$

Note that  $S(k+1)$  depends on  $S(k)$  and on the two past errors  $e(k)$  and  $e(k-1)$ .  $S_0$  is the minimum step-size.

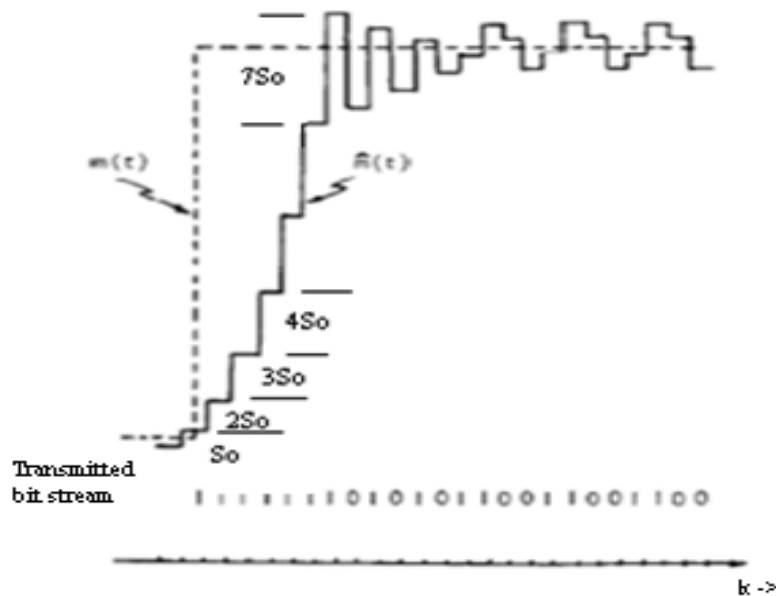

Figure 3. Adaptive delta modulation showing the changing step size and bit pattern produced using SONG algorithm.

## 2.2. Modified ABATE algorithm

The modified ABATE algorithm is another step-size adaptation algorithm and is more susceptible to slope overload than the SONG algorithm. The unique feature of this algorithm is that it is designed to adaptively follow the received signal even in a channel with high error rate of approximately  $10^{-1}$  [13]. The equation describing the modified ABATE algorithm is

$$S(k+1) = \begin{cases} [|S(k)| + S_0]e(k); & e(k) = e(k-1) \text{ and } S(k) < 8S_0 \\ |S(k)|e(k); & e(k) = e(k-1) \text{ and } S(k) = 8S_0 \\ S_0e(k); & \text{otherwise} \end{cases} \quad (3)$$

When an error occurs in the received data stream the step size processor will produce erroneous step sizes until a correctly received data transition is detected. This feature of the proper step size recovery is illustrated in Figure 4. The average number of erroneous step sizes following a received error in the modified ABATE algorithm is less than other ADM algorithms apart from SONG algorithm [12].

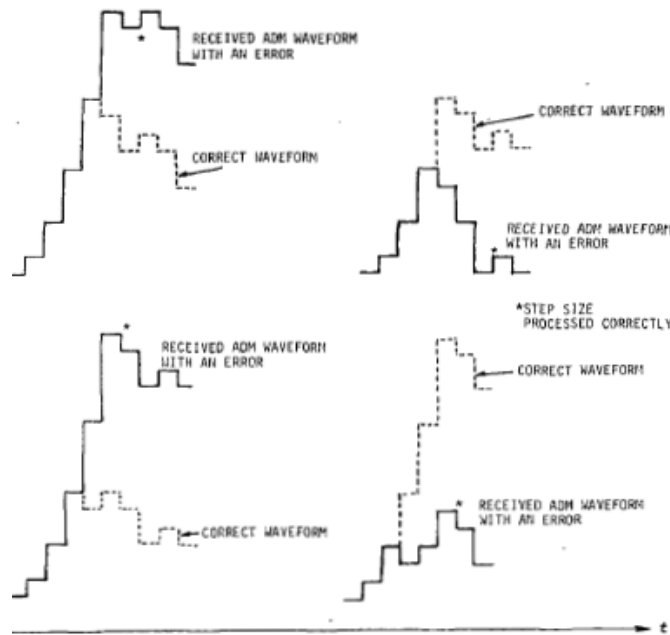

Figure 4. Modified-ABATE waveforms with channel errors showing step size recovery

### 3. The Proposed step-size adaptation

The new proposed technique for the step-size adaptation is described as

$$S(k+1) = \begin{cases} [\alpha |S(k)| + S_0] & e(k); e(k) = e(k-1) \\ [\beta |S(k)| - S_0] & e(k); e(k) \neq e(k-1) \\ & \text{and } \beta |S(k)| > S_0 \\ S_0 e(k); & e(k) \neq e(k-1) \\ & \text{and } \beta |S(k)| < S_0 \end{cases} \quad (4)$$

$\alpha$  is the adaptation parameter nearly equal to 1 but, greater than 1.  $\beta = 1/\alpha$ .

In this algorithm the rate of change of step-size in the slope-overload region can be  $S_0$  or  $\alpha S_0$  or  $\alpha^2 S_0$  etc., By proper choice of  $\alpha > 1$ , the rate of change of step-size can be made greater than  $S_0$ . It is seen that choice of  $\alpha$  gives a better performance to slope overload and the parameter  $\beta$  takes care of the granular noise as a result of which a better performance is obtained as compared to SONG and modified ABATE algorithms. This can be observed in the performance comparison described in section 4.

### 4. Performance Comparison

In this section, the computer simulation results for comparing the performance of the proposed step-size adaptation algorithm with SONG and the modified ABATE algorithms are presented.  $\alpha$  is taken as 1.1 and  $S_0=0.1$ .

Figures 5 and 6 show the performance comparison of proposed algorithm with SONG algorithm and proposed algorithm with modified ABATE algorithm respectively with sine wave of 1kHz, amplitude 3V peak with sampling frequency of 16kHz. It is seen that in both cases the proposed step-size algorithm gives a better stair case approximation compared to SONG and modified ABATE algorithms.

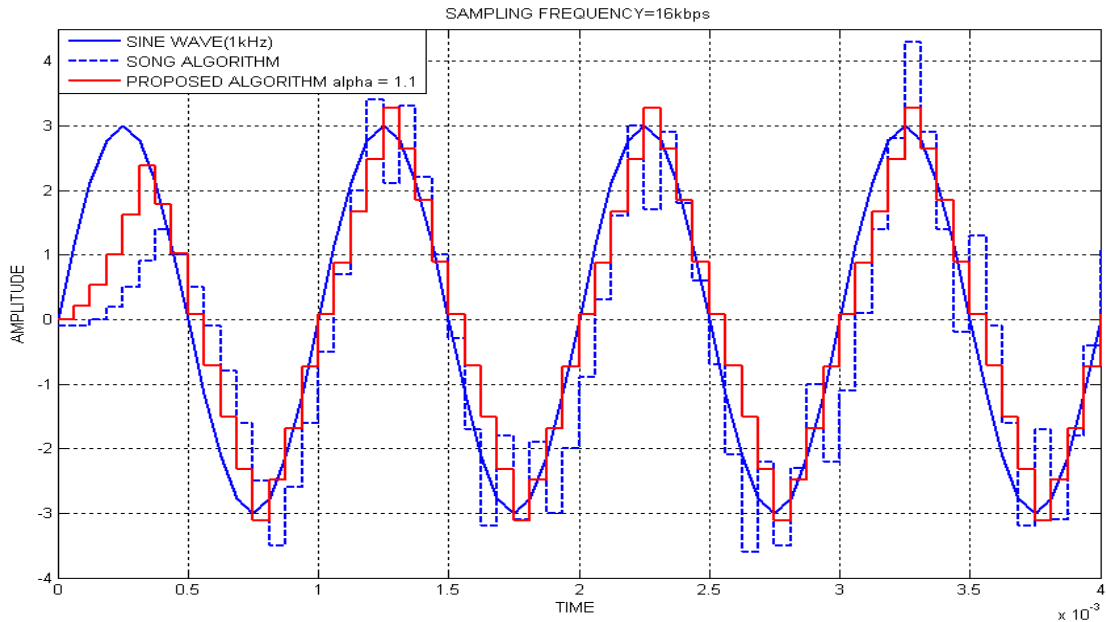

Figure 5. Performance comparison of SONG algorithm with Proposed Algorithm.

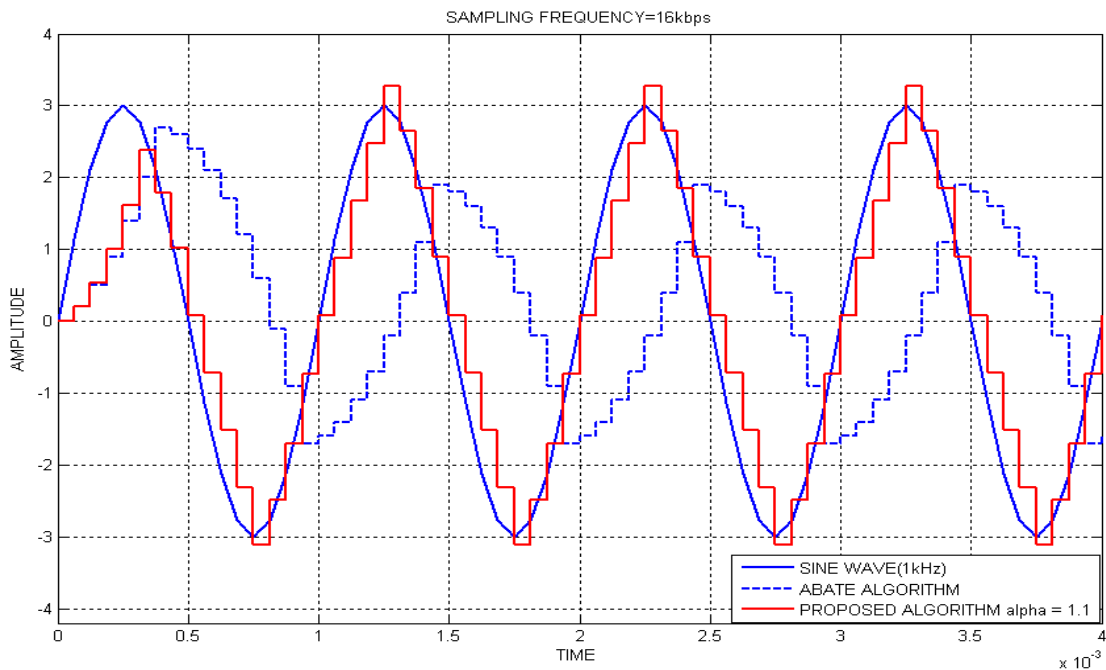

Figure 6. Performance comparison of ABATE algorithm with Proposed Algorithm.

#### 4.1 SNR Calculation

The signal-to-quantization noise ratio (SNR) of the ADM will be employed as the performance criterion for comparison [13] - [16]. In the previous section, it is seen from figures 5 and 6, for a sinusoidal signal of 1kHz and amplitude 3V, the proposed scheme performs better compared to SONG and ABATE algorithms. In this section, a sample of speech is taken as input signal and the performance is compared using SNR as criteria. The sample speech waveform in the illustration is the speech sound “i i i i” used as input as shown in Fig.2. The positive peak is 0.8 V and maximum frequency is 3.8kHz with sampling frequency of 16kHz. The SNR was calculated using standard formula

$$SNR = 10 \log_{10} \frac{\sum_{n=1}^N (x_n)^2}{\sum_{n=1}^N (x_n - \hat{x}_n)^2} \quad (5)$$

$\{x_n\}$  → Samples of original signal (speech signal)

$\{\hat{x}_n\}$  → Samples of final reconstructed signal

$(x_n - \hat{x}_n)$  → Error signal

$(x_n - \hat{x}_n)^2$  → Squared Error signal

Where N is the total number of samples of the input speech and is equal to 16000 samples.

In fig. 7(a), the performance comparison of the proposed step-size adaptation algorithm with the SONG and the modified ABATE algorithms in a noiseless channel for 16kHz is described and in fig. 7(b) the same plot of fig.7(a) is shown but the input strength is displayed for -7dB to -1dB. It is seen that the proposed step-size algorithm gives performance improvement compared to the existing algorithms, when the input strength is in the range -7dB to -1dB.

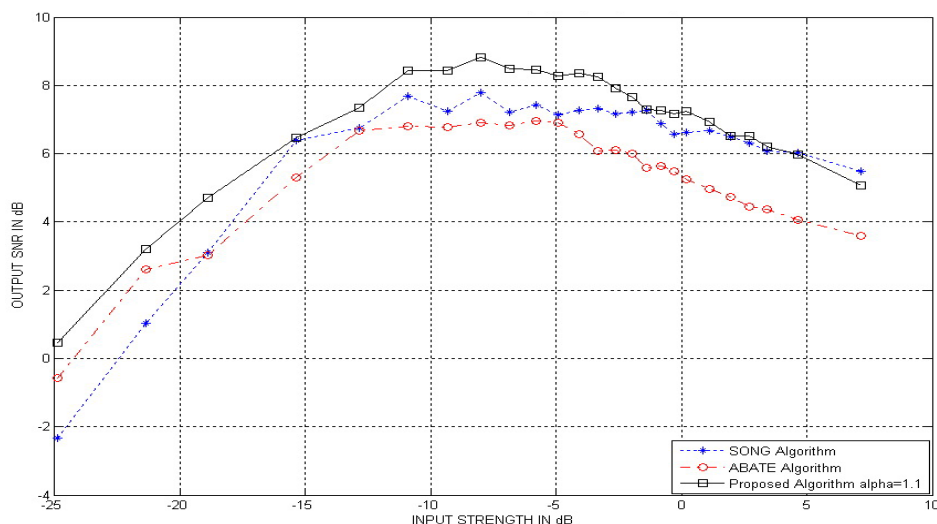

(a)

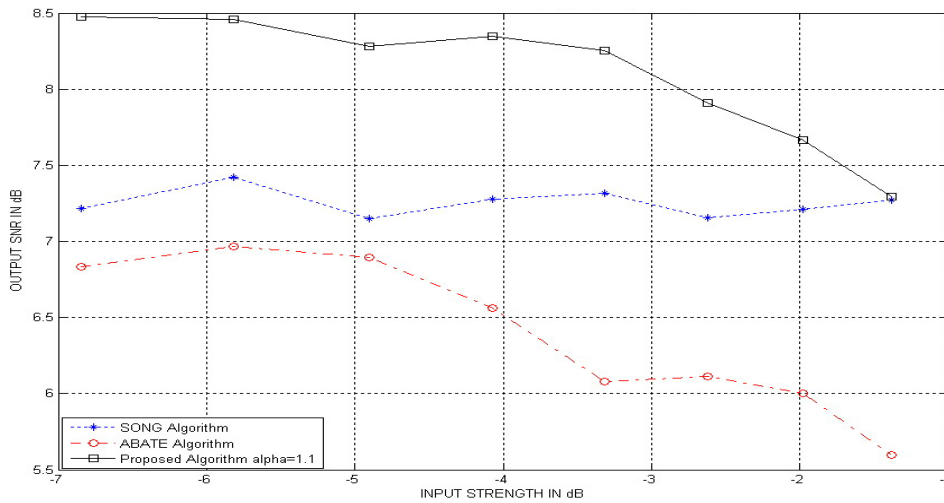

(b)

Figure 7. Performance Comparison of the proposed step-size adaptation algorithm with the SONG and the modified ABATE algorithms. (a) Plot for Input strength varied from -25dB to 10dB (b) plot for Input strength varied from -7dB to -1dB.

### 5. Pre-Processing

In this section we show that the proposed ADM has better performance than the conventional ADM [13] – [16]. Integrator and differentiator circuits are employed for pre-processing and post-processing the signals respectively. The purpose of pre-filtering is to prevent or minimize aliasing effects which can be perceptually very objectionable in speech and image coding. The band limited speech signal is integrated by employing a first order low pass filter. A first order high pass filter followed by a low pass filter to reduce noise are used in the decoder section for the purpose of differentiation and noise reduction. Conventional ADM and proposed ADM block diagrams are represented in figures 8 and 9.

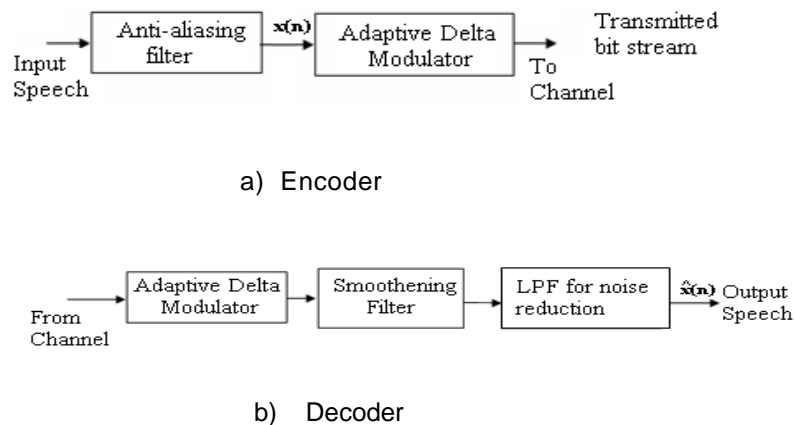

Figure 8. The block diagram of Conventional ADM



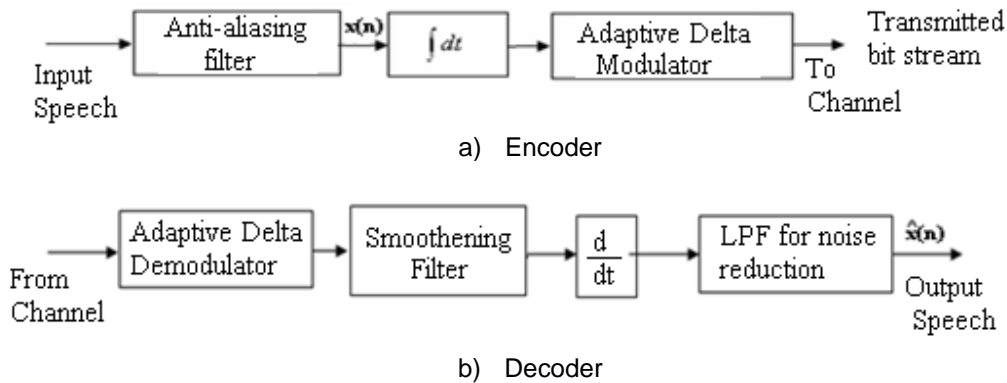

Figure 9. The block diagram of proposed ADM

The frequency response of the integrator at the transmitting end is shown in fig. 10(a). and the differentiator at the receiver side in fig.10(b). At the receiver, the differentiator is followed by a low pass filter (LPF) for noise reduction.

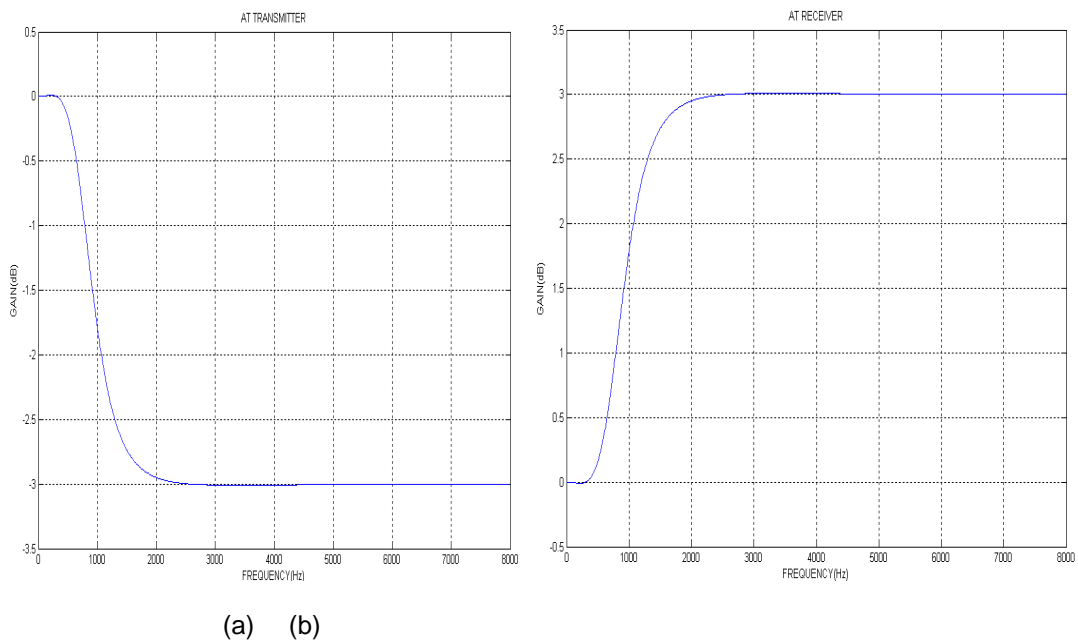
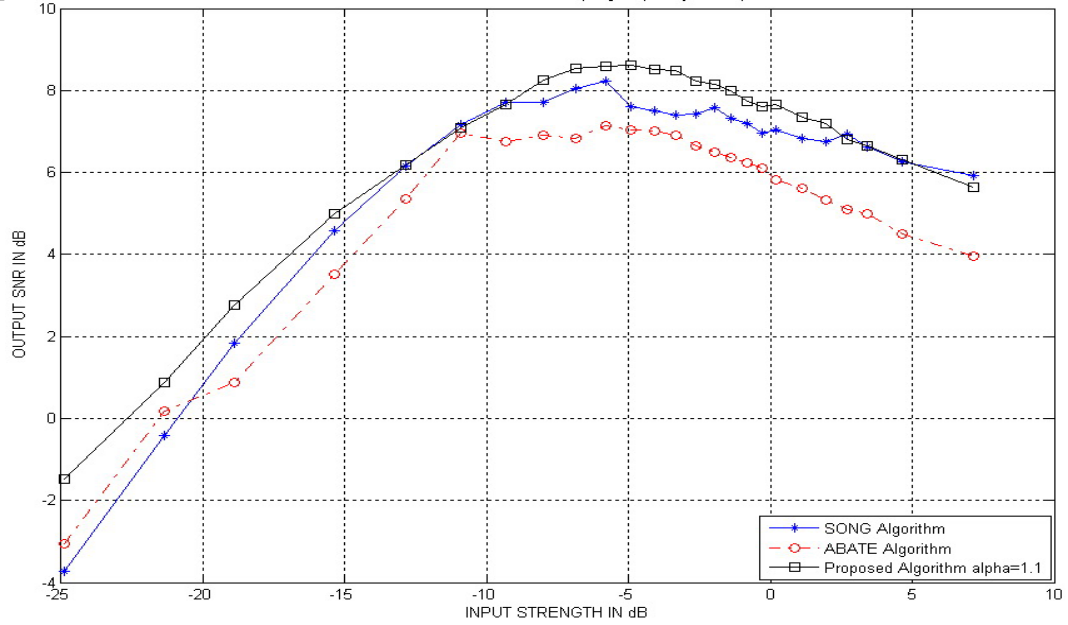

Figure 10. (a). Frequency response of Pre-Processor (Integrator) at the transmitter  
(b). Frequency response of the Differentiator at the receiver.

### 5.1. Performance comparison with pre-processor

The same sample speech waveform “i i i i” shown in Fig.2 with the positive peak of 0.8 V and maximum frequency 3.8 kHz is used as input. The SNR performance with pre-processor and the ADM systems discussed earlier like SONG, modified ABATE and proposed step-size adaptation algorithm with  $\alpha = 1.1$  in a noiseless channel for 16kHz is

shown in figure 11(a) and figure 11(b). We observe that the ADM with pre-processing gives performance improvement compared to the schemes given by SONG, modified ABATE and proposed step-size adaptation algorithm with  $\alpha = 1.1$



(a)

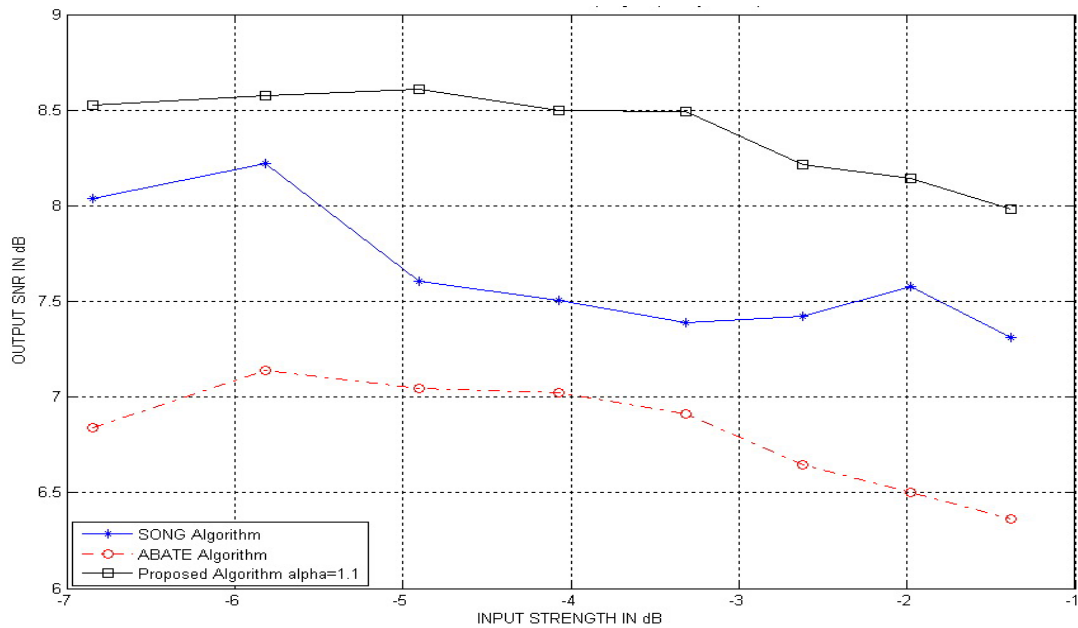

(b)

Figure 11. Performance Comparison of the ADM with pre-processing with the SONG, modified ABATE and the proposed algorithms. (a) plot for Input strength varied from -25dB to 10dB (b) plot for Input strength varied from -7dB to -1dB.

## 6. Conclusion

Simulations are carried out for all the schemes.  $S_0$  is taken as 0.1 and  $\alpha = 1.1$ . Simulations have also confirmed that with the input strength for -5dB to -3dB on an average a 1.1dB performance gain in the SNR is got for the new step-size adaptation algorithm compared to the SONG and a 1.5dB performance gain compared to the modified ABATE algorithm. Next, with pre-processing and with the same input strength, on an average there is a 1.4dB performance improvement in the SNR for the new step-size adaptation algorithm as compared to the SONG and a 1.7dB improvement compared to the modified ABATE algorithm.

## References

- [1] F.de Jager, "Delta Modulation, a method of PCM transmission using a one-unit code", Philips Res. Rept., vol. 7, 1952.
- [2] Van De Weg, H. "Quantization Noise of Single Integration Delta Modulation System with a N-Digit Code", Philips Res. Rept., 367-385, October (1953).
- [3] Goodman, D.J. "Delta Modulation Granular Quantizing Noise", J. Bell Syst.Tech., 52, 387-422, March (1973).
- [4] Greenstein, L.J. "Slope-Overload Noise In Linear Delta Modulation With Gaussian Inputs", J. Bell Syst. Tech. 52, 387-422, March (1973)
- [5] O'Neal, J.B. "Delta Modulation Quantizing Noise: Analytical and Computer Simulation Results for gaussian and Television Input Signals", J. Bell Syst.Tech. 45, 117-142, January (1966).
- [6] Slepian, D. "On Delta Modulation", J. Bell Syst. Tech. 51, 2101-2137, December (1980).
- [7] Tomozawa, A. and Kaneko H. "Companded Delta Modulation for Telephone Transmission", IEEE Trans. Commun.Tech., Vol.COM-16, pp.149-157, February (1968).
- [8] Jhonson,F.B. "Adaptive Quantization with a One-Word Memory", J. Bell Syst. Tech. 52, 1119-1144, September (1973).
- [9] Jayanth N.S "Adaptive Delta Modulation with a 1-bit memory", J. Bell Syst. Tech. 49, issue 3, 321-342, March (1970).
- [10] C. L. Song, D. L. Schilling, and Garodnick J. "A Variable Step- Size Robust Delta Modulator", IEEE Trans. Comm. Tech., Vol. COM-19, pp. 1033-1044, December (1971).
- [11] Abate, J.E. "Linear and adaptive delta modulation", Proceedings of the IEEE Vol 55, pp. 298 – 308, March (1967).
- [12] Donald L, Schilling, Joseph gorodnick and Harold A Vang. "Voice encoding for the space shuttle using ADM", IEEE Trans. on Communications, vol. COM-26, no. 11, November (1982).
- [13] K.Yao, K K Paliwal and Nakamura S. "Noise adaptive speech recognition with acoustic models trained from noisy speech evaluated on Aurora-2 database", Proc. Intern. Conf. Spoken Language Processing, Denver, Colorado, USA, pp.2437-2440, September (2002).
- [14] Ming Yang. "Low bit rate speech coding", Potentials, IEEE, vol 23, No. 4, pp. 32-36, October-November (2004).
- [15] Gibson J D. "Speech coding methods, standards and application", IEEE Circuits and Systems Magazine, Vol. 5, No. 4, Pp. 30-49, fourth Quarter (2005).
- [16] Hui Dong, Gibson J D. "Structures for SNR scalable speech coding", IEEE Trans on Audio, Speech and Language Processing, vol. 14, No.2, pp.545-557, March (2006)

## Authors



**B.K.Sujatha** received the Bachelors degree in electronics and communication engineering from Mysore University, Karnataka, India, in 1987, M.E degree in Electronics Engineering from Bangalore University, Bangalore, in 1993, and is currently working towards the Ph.D degree at Visvesvaraya Technological University, Karnataka, India. She is currently working as Assistant Professor with the department of Telecommunication Engineering, M.S. Ramaiah Institute of Technology, Bangalore. She had served as teaching faculty at SJGIT, Bangalore for 16 years up to 2004. Her research areas include speech & audio signal processing, statistical signal processing and modeling, multi-rate systems.



**P. S. Satyanarayana** received the B.E and M.S degrees in electronics and communication engineering, in 1972 and 1975 respectively, and the Ph. D degree in electrical communication from Indian institute of Science, Bangalore, in 1987. He is currently working as a Professor with the department of electronics and communication engineering, B.M. Sreenivasaiah College of Engineering, Bangalore. His research areas include Information theory and error control coding, adaptive signal processing, digital communication and wavelet transforms.



**K.N.Hari Bhat** received the B.E. degree with honours from Mysore University in 1966, M.Tech and Ph. D degrees in Electronics and Communication Engineering from Indian Institute of Technology, Kanpur, in 1973 and 1986, respectively. He is currently the head of the department of Electronics and Communication Engineering, Nagarjuna college of Engineering and Technology, Bangalore. He was with the Karnataka Regional Engineering College, Surathkal (now known as National Institute of Technology) for more than 30 years upto 2001. He has co-authored two books in the area of Communications. His areas of interest are analog and digital communication and cryptography.